

# 20 mm Diameter Incremental Rotary Encoders



## E20 Series CATALOG

For your safety, read and follow the considerations written in the instruction manual, other manuals and Autonics website.

The specifications, dimensions, etc. are subject to change without notice for product improvement. Some models may be discontinued without notice.

### Features

- Ultra-compact (Ø 20 mm) housing and lightweight (35 g) design
- Easy installation in tight or limited spaces
- Low shaft moment of inertia
- Various resolutions: 100, 200, 320, 360 pulses per revolution
- Various control output options
- Power supply: 5 VDC $\pm$  5%, 12 VDC $\pm$  5%

### Ordering Information

This is only for reference, the actual product does not support all combinations. For selecting the specified model, follow the Autonics website.

E20 ① ② - ③ - ④ - ⑤ - ⑥ - ⑦

#### ① Shaft type

S: Shaft type  
HB: Hollow Built-in type

#### ② Shaft outer diameter / Shaft inner diameter

2: Ø 2 mm  
2.5: Ø 2.5 mm  
3: Ø 3 mm

#### ③ Resolution

Number: Refer to resolution in 'Specifications'

#### ④ Output phase

3: A, B, Z  
6: A,  $\bar{A}$ , B,  $\bar{B}$ , Z,  $\bar{Z}$

#### ⑤ Control output

N: NPN open collector output  
V: Voltage output  
L: Line driver output

#### ⑥ Power supply

5: 5 VDC $\pm$  5%  
12: 12 VDC $\pm$  5%

#### ⑦ Connection

R: Axial cable type  
S: Radial cable type

### Product Components

Shaft type	Shaft type	Hollow Built-in type
Product Components	Product, Instruction manual	
Bolt	× 4	× 2
Coupling	× 1	-
Bracket	-	× 1

### Specifications

Model	E20□□-□-3-N-□-□	E20□□-□-3-V-□-□	E20□□-□-6-L-5-□
Resolution	100 / 200 / 320 / 360 PPR model		
Control output	NPN open collector output	Voltage output	Line driver output
Output phase	A, B, Z	A, B, Z	A, $\bar{A}$ , B, $\bar{B}$ , Z, $\bar{Z}$
Inflow current	≤ 30 mA	-	≤ 20 mA
Residual voltage	≤ 0.4 VDC $\pm$	≤ 0.4 VDC $\pm$	≤ 0.5 VDC $\pm$
Outflow current	-	≤ 10 mA	≤ -20 mA
Output voltage	-	-	≥ 2.5 VDC $\pm$
Response speed <sup>01)</sup>	≤ 1 μs		≤ 0.5 μs
Max. response frequency	100 kHz		
Max. allowable revolution <sup>02)</sup>	6,000 rpm		
Starting torque	≤ 5 × 10 <sup>-4</sup> N m		
Inertia moment	≤ 0.5 g · cm <sup>2</sup> (5 × 10 <sup>-8</sup> kg · m <sup>2</sup> )		
Allowable shaft load	Radial: ≤ 200 gf, Thrust: ≤ 200 gf		
Unit weight	≈ 35 g		
Approval	CE EAC	CE EAC	EAC

01) Based on cable length: 1 m, I sink: 20 mA

02) Select resolution to satisfy Max. allowable revolution ≥ Max. response revolution  
[max. response revolution (rpm) =  $\frac{\text{max. response frequency}}{\text{resolution}} \times 60 \text{ sec}$ ]

Model	E20□□-□-3-N-□-□	E20□□-□-3-V-□-□	E20□□-□-6-L-5-□
Power supply	5 VDC $\pm$ 5% (ripple P-P: ≤ 5%) / 12 VDC $\pm$ 5% (ripple P-P: ≤ 5%) model		5 VDC $\pm$ 5% (ripple P-P: ≤ 5%)
Current consumption	≤ 60 mA (no load)		≤ 50 mA (no load)
Insulation resistance	Between all terminals and case: ≥ 100 MΩ (500 VDC $\pm$ megger)		
Dielectric strength	Between all terminals and case: 500 VAC~ 50 / 60 Hz for 1 minute		
Vibration	1 mm double amplitude at frequency 10 to 55 Hz (for 1 minute) in each X, Y, Z direction for 2 hours		
Shock	≤ 50 G		
Ambient temp.	-10 to 70 °C, storage: -20 to 80 °C (no freezing or condensation)		
Ambient humi.	35 to 85%RH, storage: 35 to 90%RH (no freezing or condensation)		
Protection rating	IP50 (IEC standard)		
Connection	Axial / Radial cable type model		
Cable spec.	Ø 3 mm, 5-wire (Line driver output: 8-wire), 1 m, shield cable		

## Dimensions

- Unit: mm, For the detailed drawings, follow the Autonics website.

### ■ Shaft type

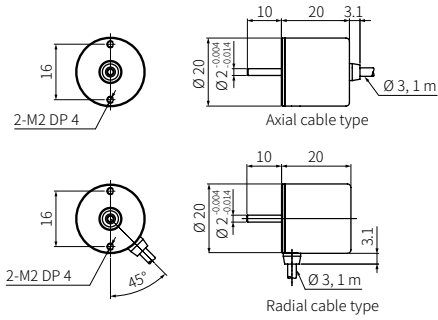

### ■ Hollow Built-in type

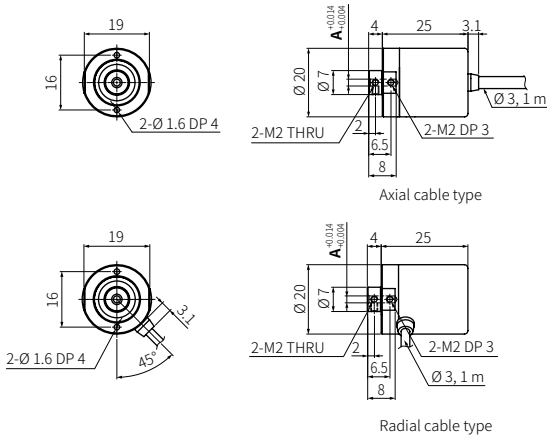

	A
E20HB2	Ø 2
E20HB2.5	Ø 2.5
E20HB3	Ø 3

### ■ Bracket

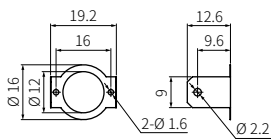

### ■ Coupling

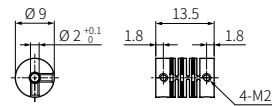

- Parallel misalignment:  $\leq 0.15$  mm
- Angular misalignment:  $\leq 2^\circ$
- End-play:  $\leq 0.2$  mm