

# REVVO SERIES

# ELECTRIC MOTORS



## rotomotive

*Looks good. performs better.*

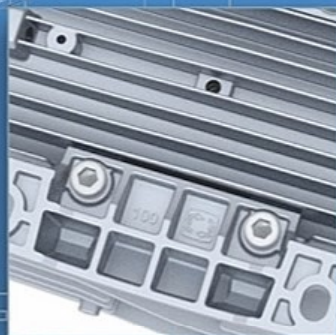
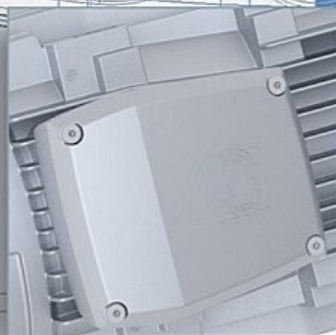
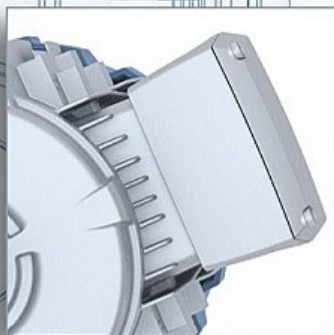



Rotomotive Powerdrives India Ltd is an Italian joint venture company operating in India since 2006. It has access to European technology and know-how from Motive srl, one of the joint venture partners and sources parts and components from Indian suppliers. We have a modern manufacturing facility in Gujarat, India. Rotomotive has the capacity to design, prototype and manufacture custom motors for various applications.

Our modern manufacturing plant has advanced machinery for automatic winding, trickle and vacuum pressure impregnation, precise balancing, conveyORIZED assembly, enclosed painting lines, automatic testing facilities with all components bar coded for traceability, consistent quality and low production time.

We also have an advanced testing facility for type testing motors and gearboxes which enables us to plot accurate speed torque curves and carry out temperature rise tests and other type tests as per IEC 60034/IS:12615.

Our Manufacturing facility in India



Lean Assembly Line



Surge Impedance Test



Precise Balancing



Motor Type Testing



Brake Motor Testing



CMM for mechanical inspection

## TECHNICAL CHARACTERISTICS

Rotomotive asynchronous three phase Revvo series motors are built with dimensional conformance to Indian Standard IS:1231, IS: 2223 & International standard IEC 72-1.

The mounting positions as per IS : 2253 and IEC 34-7 are B3, B5, B14 and B35.

Rotomotive motors are totally enclosed, and fan cooled. Non-standard versions in TENV construction are also available on request.

The frame sizes upto 132 are made from light weight die cast aluminium alloy and from size 160 up to 355 the frame and end-covers are made from cast iron.

All motors are  
multiple voltage  
multi-frequency 50/60Hz,  
F class insulation, (H class on request)  
S1 continuous duty service,  
IP55 protection, (IP66 on request)  
IE2 or IE3 efficiency class (IEC 60034-30)  
tropicalized winding

IE 2

IE 3

IE 4 (PMSM)

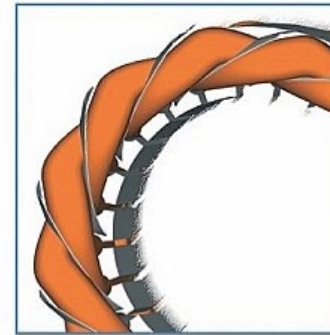
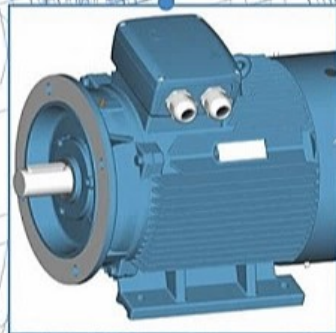

The windings are vacuum impregnated under pressure with F class insulating enamel to ensure high resistance to electrical, thermal and mechanical stresses.

The phases are further isolated by another layer of phase separator insulating film to protect the motors from the voltage spikes that usually occur when the motor is controlled by an inverter.

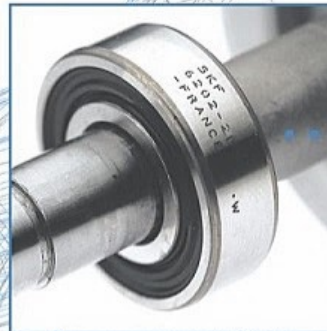

Rotomotive motors use shielded bearings with C3 clearance to ensure low noise and higher reliability. The rotor is dynamically balanced according to IS : 12075 as well as IEC 34-14 and ISO 9921/ ISO 8821 norms.

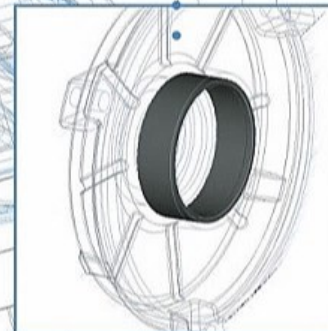

Securing the bearings into their seats with internal circlips prevents them from moving axially. From frame size 90, a steel insert is provided in the bearing seats on both the aluminium end-covers, so as to provide high resistance to the radial mechanical forces

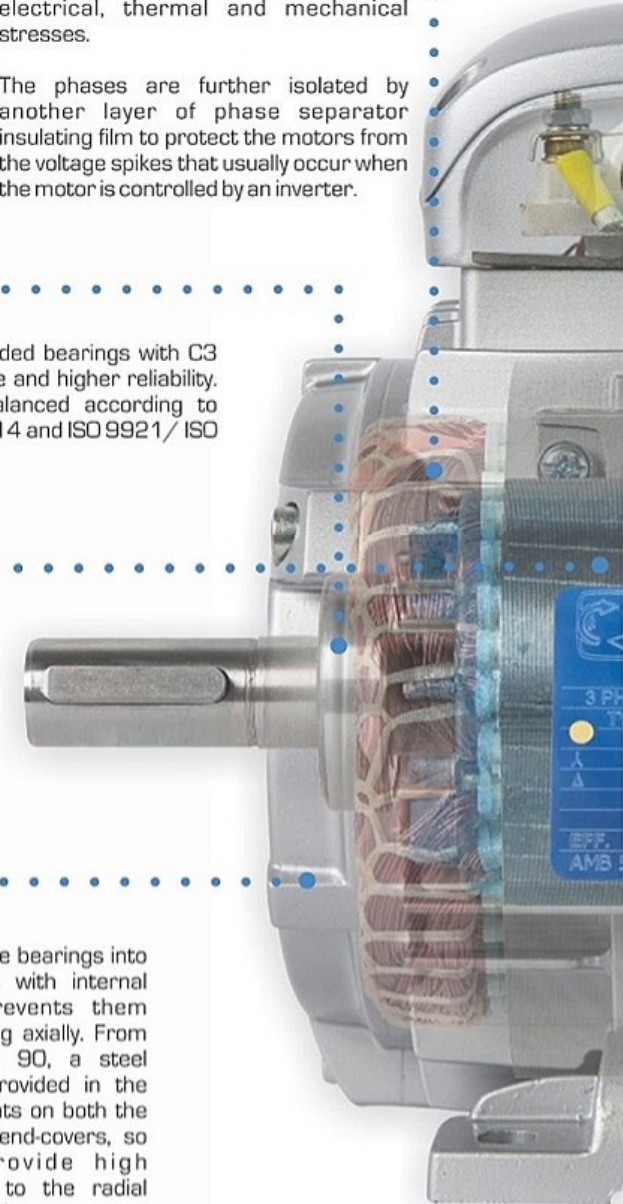

PATENTED

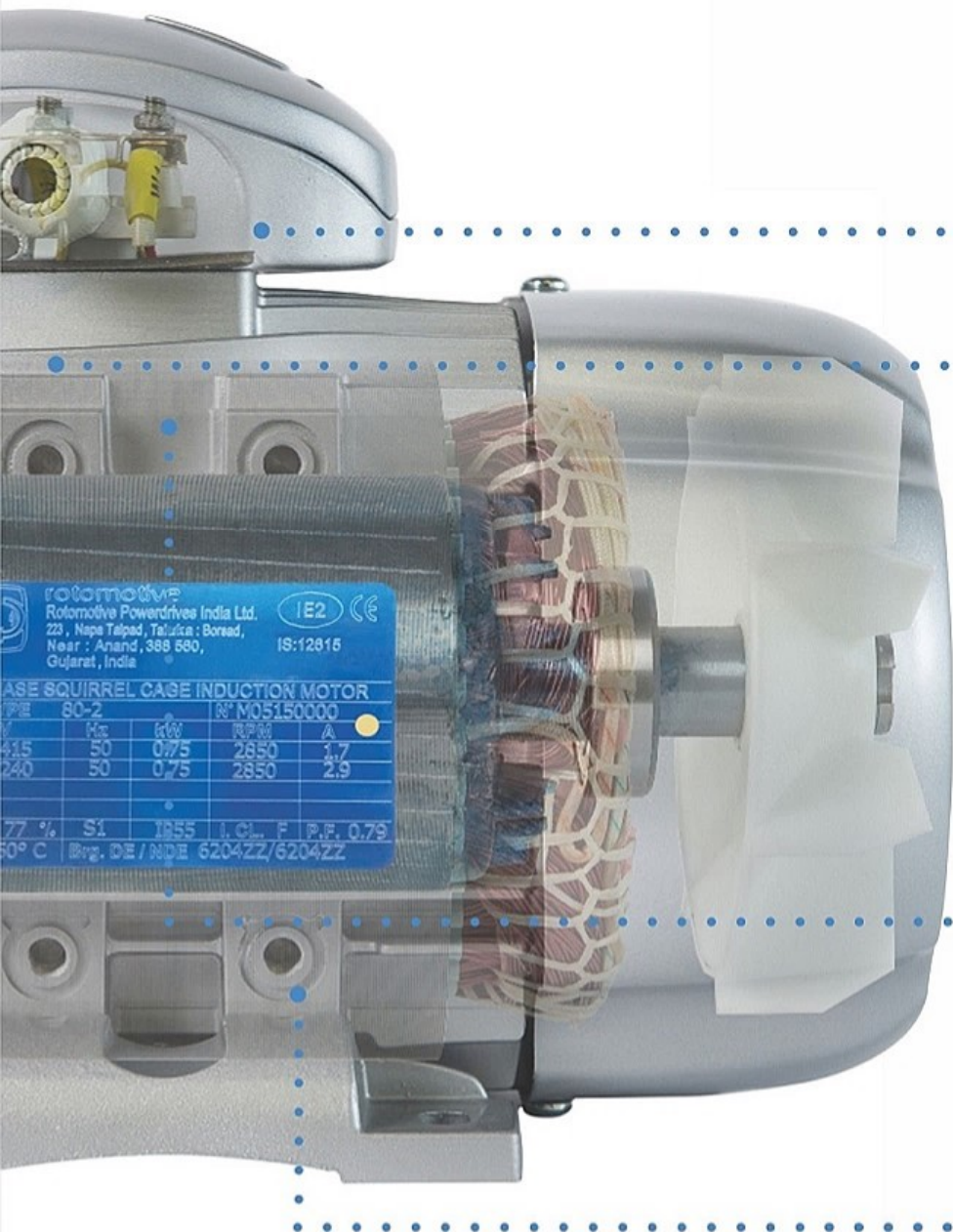

rotomotive  
 Rotomotive Powerdrives India Ltd.  
 223, Nape Talpad, Taluika : Borsad,  
 Near : Anand, 388 580,  
 Gujarat, India

IE2 CE  
 IS:12815

BASE SQUIRREL CAGE INDUCTION MOTOR

TYPE	80-2	N° M05150000		
	Kvs	gr%	RPM	A
415	50	0,75	2850	1,7
240	50	0,75	2850	2,9

77 % S1 1855 I.C.L. F P.F. 0,79  
 50° C Brg. DE / NDE 6204ZZ/6204ZZ



Cable gland can be easily moved on both the sides of the terminal box, and other end can be sealed using screwed cap.



The terminal box can be rotated of 360° in steps of 90°

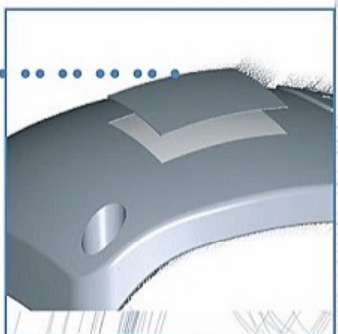

To protect against corrosion and rusting, Rotomotive motors are painted with RAL9006 silver colour upto 132 frame and from frame size 160 onwards, motors are painted with RAL 5007 blue colour.

From size 160 and up, due to the high torque, the motors are fixed with feet that are die-casted with the iron frame

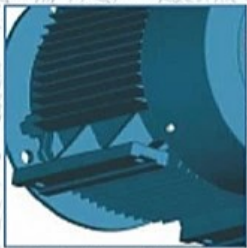

Superior efficiency and performance is achieved through use of low loss CRNO magnetic laminations instead of the usual Semi Processed/Decarb material. CRNO laminations enable higher efficiency, lower heating, promote energy saving, age slower and reduce thermal stresses on insulation materials.

From frame size 56 to 132, Feet and the terminal box can be moved to the right or left

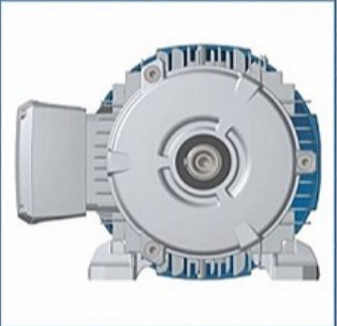
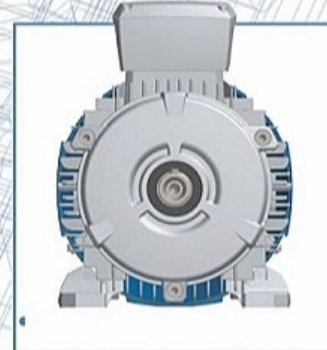

## EFFICIENCY

Limited energy resource and high interest cost of addition of new generation capacity is leading to an increase in the cost of electrical energy in India. The Bureau of Indian standards, with an aim to promote energy conservation has specified efficiency levels for motors termed as 'Energy Efficient motors' in its standard IS: 12615. These are categorized as IE2 & IE3.

Rotomotive motors are designed and manufactured to meet all the requirements of the standard IS: 12615 as well as the European agreement issued by the European commission and CEMEP (European Committee of Manufacturers of Electrical Machines and Power Electronics). The prime benefits of using Energy Efficient motors are:

### IMMEDIATE SAVING IN POWER COST:

Though actual savings may depend on type of use and duration, generally, IE3 level motors reduce the power cost by about 20%. For instance, a 15 KW motor for an operation period of 6,000 hours per year can save about 2 MWhr or more, resulting in a **direct saving of about Rupees 8000 per year.**

### HIGHER DURABILITY:

Higher efficiency motors heat less slowing down the aging of the insulating materials and thereby prolonging their reliability and life. Considering an average operation of 2500 hours/ year for motors up to 15KW and 4000 hours / year for motors rated higher than 15KW, the expected life is approximately 12 years.

### ENVIRONMENT FRIENDLY:

Efficiency IE3 motors guarantee great energy and cost savings, and consequently reduce the use of resources which generate CO<sub>2</sub> emissions. This eventually improves the quality of our environment.

### HOW TO MAKE A MORE EFFICIENT MOTOR?:

High efficiency can be seen in many ways: like the relation between output power and input power or like a measure of the losses that occur when converting the electric power into mechanical energy. From another perspective, energy efficient motors consume less energy to produce the same torque at the shaft.

An energy efficient motor is the result of use of low loss materials, precise construction, lower frictional losses, dynamically balanced rotor, and lesser air-gap between rotor and stator. **The main design factors are based on the choice of the type of lamination and windings with a higher conductor diameter.** Among all materials that compose a motor, quality of laminations have the highest influence on performance.

### SILICON MAGNETIC LAMINATIONS

Rotomotive motors are made with **CRNO** magnetic lamination sheets, rather than the usual **Semi Processed/Decarb** lamination sheets.

Apart from the choice of material, the thickness of laminations has a significant impact on performance.

In fact, thinner is the sheet higher is the performance.

The lamination sheets **Semi Processed/Decarb** can reach up to 1mm thickness.

**CRNO** magnetic lamination sheets have a 0.5mm maximum thickness

Material composition and thickness of magnetic laminations result in a very low Watts loss/kg.

**Lower specific losses mean less magnetising current for the same Power and torque (thus lesser heating)**

EURO NORM	Watts loss/Kg at 1T	Watts loss/Kg at 1.5T
105-84	1.70	4.00

data at 400V 50Hz

Instead, no standard prescribes a maximum watts loss factor for **Semi processed/Decarb** lamination sheets although it is considered to be generally double of **CRNO** lamination sheet.

There is ofcourse a wide variation even in these values.

Amongst all the raw materials that are used in an asynchronous electric motor, laminations have the greatest contribution in determining the performance.

The main advantages of use of silicon steel laminations are:

- Higher Efficiency
- Better guarantees on the quality consistency, and assurance of achievement of efficiency tolerances specified in International norms.

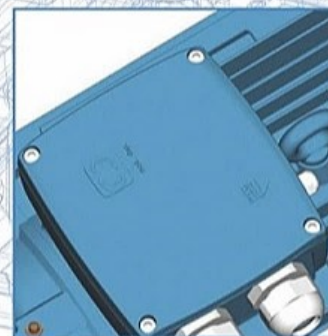

## PROTECTION TYPE

The protection against accidental human contact, ingress of dust or the entry of water is specified in IS: 4691 by an acronym of 2 letters followed by 2 numbers.

### Scheme of IP index for Protection

1<sup>st</sup> Digit. Protection against harmful ingress of solid matter and dust.

2<sup>nd</sup> Digit. Protection against harmful entry of water

Rotomotive motors are with IP55 protection

1 <sup>st</sup> number	2 <sup>st</sup> number
0	no protection
1	Protection against solid objects larger than 50mm
2	Protection against solid objects larger than 12mm
3	Protection against solid objects larger than 2.5mm
4	Protection against solid objects larger than 1mm
5	Protection against dust (no deposits of harmful material)
6*	Complete protection against ingress of dust.

1 <sup>st</sup> number	2 <sup>st</sup> number
0	no protection
1	Protection against vertical water drops [condensation]
2	Protection against water drops fall upto 15 from the vertical
3	Protection against water drops upto 60 from the vertical
4	Protection against water splashes from all directions
5	Protection against water jet from a nozzle of 6.3mm D with a water capacity 12.5 lt/min at a distance of maximum 3m for 3min
6*	Protection against jets of water comparable to heavy seas.

\*OPTIONAL

## WORKING CONDITIONS

### HUMIDITY:

Rotomotive motors are suitable for operating in conditions of relative humidity between 30% and 95% (without condensation). Damaging effects of occasional condensation must be avoided by adequate equipment design or if necessary by additional measures (for example built in heating or air conditioning equipment, drain holes).

### ALTITUDE AND TEMPERATURE:

The ratings indicated are at altitudes upto 1000mt above sea level and room temperature between +5°C and +50°C for motors having a rated power below 0.6KW or between -15°C and +50°C for motors having a rated power equal to or greater than 0.6KW (as per IS:12615/IEC 34-1).

Power output decreases by 10% for every 10°C increase in ambient temperature and 8% for each 1000mt increase in altitude.

It is not necessary to reduce the rated power if at an altitude higher than 1000mt and lower than 2000mt there is a max ambient temperature of 30°C or in altitudes from 2000mt to 3000mt there is a max ambient temperature of 19°C. This also holds true when the motors are operated at higher ambients, upto 50°C but at lower altitude.

### VOLTAGE AND FREQUENCY VARIATION:

The maximum permissible variation in the supply voltage is +,-10%. Frequency variation of +,-5% is permissible and overall cumulative variation i.e the sum of variation of voltage and frequency +,-10% is allowed.

### INSULATION:

The windings are vacuum impregnated under pressure with a layer of F class insulating enamel to ensure high resistance to electrical, thermal and mechanical stresses.

Slot insulation comprising of N.P.N insulating paper warps entirely around the coil side insulating the conductor from the body.

The phases are further isolated from each other by another layer of N.P.N phase separator paper to protect the motors from voltage peaks that usually occur when the motor is controlled by an inverter.

Maximum operating temperatures permitted for stator windings for each insulation class indicated on the motor name-plate.

Class	$\Delta T$ (°C)	T max (°C)
A	60+5°	105
E	75+5°	120
B	80+5°	130
F	105+5°	155
H	125	180

Rotomotive motors are designed to ensure that maximum temperature of the windings do not surpass the permissible temperature of their class even under S1 continuous duty service.

Almost all ratings of Rotomotive motors having class F insulation have the maximum temperature rise limited to the values permitted in Class B over an ambient of 50°C. Motors are suitable for 1.1 service factor with Class F temperature rise.

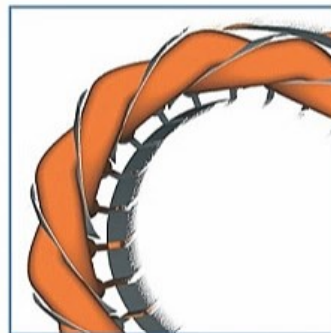

## ROTO MOTIVE MOTORS PROTECTION

Protections for the motors must be chosen based on the specific running condition according to the standard EN 60204-1

- Protection for motors with a shaft power greater than or equal to 0.5 KW with continuous S1 duty. This protection may be achieved by means of a thermal cut out relay, which can automatically cut off the supply.
- Protection against peak currents by magnetic relay that controls a contactor or by fuses. These must be set to the locked rotor current.
- If the application requires protection against excessive speed of the electric motor in situations where the mechanical load may drive the electric motor itself and thereby create a hazardous situation.
- If special conditions or synchronized operation with other machines or parts of machines require it, protection against power failures or dips by means of a minimum voltage relay that controls a contactor.

The electrical protections on the motor power line may not be sufficient to protect against overloads. If the ambient temperature increases, the motor overheats but the electrical conditions do not change which inhibits line protections. Installing built-in thermal protections on the windings solves this problem.

### PTO bimetallic device:

This is a normally closed electromechanical device that opens electrically. When the threshold temperature is reached it automatically resets when the temperature falls below the threshold level. Bimetallic devices are available with various temperature ratings and without automatic reset as per EN 60204-1

### PTC thermistor device:

This device promptly changes its resistance once the threshold temperature is reached. ROTOMOTIVE motors from frame size 180 to 355L are equipped with 3 PTC thermistors in the winding with cut-off temperature of 150°C in Class F motors (standard) or 180°C in H Class motors.

### PT100 device:

This is a device that continuously changes its resistance according to the temperature. It is useful for continuous measurement of the winding temperatures using electronic equipment.



## WIRING DIAGRAMS

Rotomotive three phase motors can be connected "Star" or "Delta"

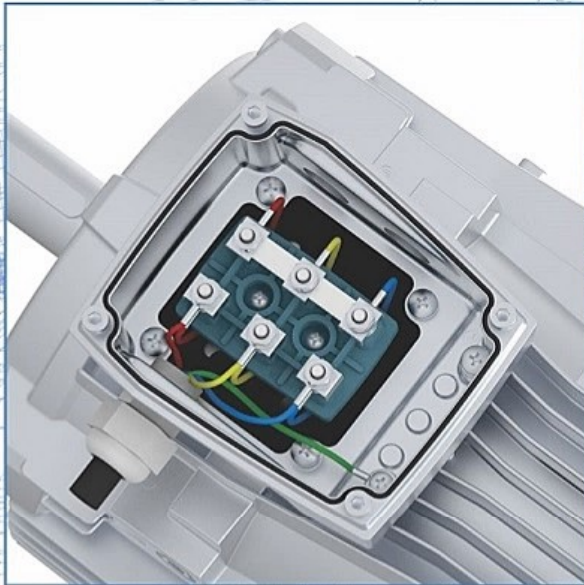

### STAR CONNECTION:

Star connection is obtained by connecting together the terminals W2, U2, V2 and supplying the terminals U1, V1, W1

The phases current and voltage are respectively

$$I_{ph} = I_n$$

$$V_{ph} = V_n / \sqrt{3}$$

Where  $I_n$  is the supply line current and  $V_n$  is the supply line voltage of star connection

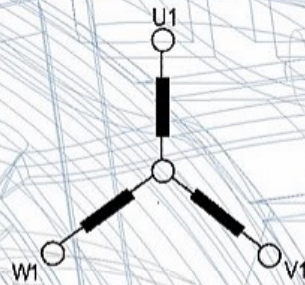

The following voltages and frequencies are possible by connection the three phase Rotomotive motors having S1 cycle in either Star OR Delta. Typical tolerances for motors of 415V, 50Hz rating are shown.

KW	Hz	Volts		
				Tolerance
Up to 2.2 KW	50 ± 5 %	230	400	+ 14 / - 7 %
		220	380	+ 15 / - 2 %
		240	415	+ 10 / - 10 %
	60 ± 5 %	260	440	+ 15 / - 6 %
		265	460	+ 10 / - 10 %
		280	480	+ 5 / - 14 %
Above 2.2 KW	50 ± 5 %	400	690	+ 14 / - 7 %
		380	660	+ 15 / - 2 %
		415	720	+ 10 / - 10 %
	60 ± 5 %	440	760	+ 15 / - 6 %
		460	795	+ 10 / - 10 %
		480	830	+ 5 / - 14 %

Voltages or tolerance other than these available on request

### DELTA CONNECTION:

Delta connection is obtained by connecting the end of a phase with the beginning of the following one.

The phase current  $I_{ph}$  and the phase voltage  $V_{ph}$  are respectively:

$$I_{ph} = I_n / \sqrt{3}$$

$$V_{ph} = V_n$$

Where  $I_n$  and  $V_n$  are referred to Delta connection.

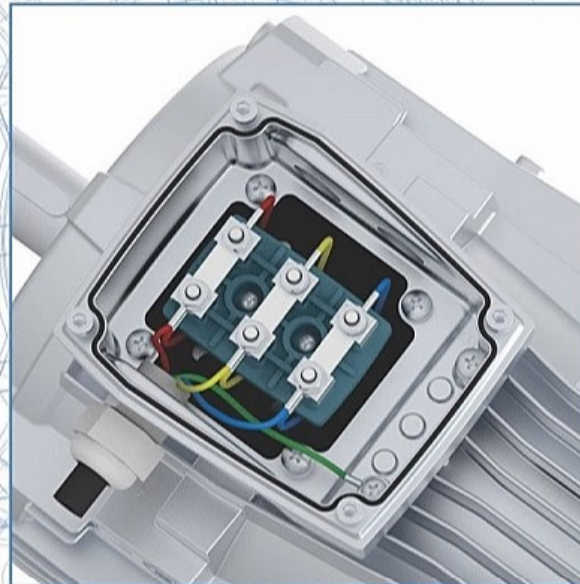
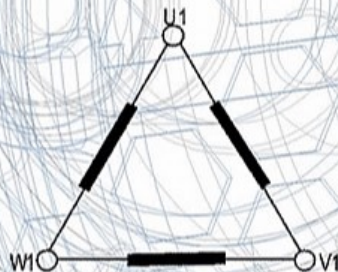

The general electrical specifications are listed in the performance charts that follow. To understand their contents, the following general definitions are provided.

**Rated Power:**  
It is the Electrical equivalent of mechanical power measured at the shaft and expressed according to the terminology of International Standards Committees, in Watts or Kilowatts. However it is still common to refer to power in terms of Horsepower (HP).

**Rated Voltage:**  
The voltage to be applied to the motor terminals in accordance with the specifications listed in the following tables

**Frequency:**  
All electrical data in this catalogue refer to three phase induction motors at 50 Hz. These may be connected to 60 Hz taking into account the multiplier coefficients in the table below

**Rated Current:**  
"In" is the rated current expressed in Amperes, drawn by the motor when supplied at rated voltage and delivering the rated power. In the following tables the rated currents are referred to a Voltage supply of 415V. For other voltage ratings, the absorbed rated current can be considered inversely proportional to the voltage supply. EX:

Volt	240	400	415	440	690
In	1.74	1.04	1.0	0.94	0.60

**Over Load Current:**  
Rotomotive motors can also withstand temporary overloads, with current increases of 1.5 times the rated current for 2 minutes.

rated voltage at 50Hz	Volt at 60Hz	rated power W	rpm	In	Ia In	Ca Cn	Cmax Cn
240	240	1.1	1.2	1.15	0.9	0.9	0.9
240	260	1.2	1.2	1	1	1	1
415	415	1	1.2	1.2	0.8	0.8	0.8
415	440	1.06	1.2	1.1	0.87	0.87	0.87
415	460	1.2	1.2	1	1	1	1
415	480	1.25	1.2	1	1.1	1.1	1.1

for further information, see chapter "wiring diagrams" at page 9

**Starting current (or locked rotor current):**  
In the performance charts the starting current "Is" is indicated as a multiple value of the rated current [Is/In]

**Synchronous Speed:**  
Synchronous Speed (Ns) is expressed in rpm and it is obtained by the formula  

$$N_s = (120 \times f) / P$$
 f= supply frequency Hz  
 P= number of poles pairs

**Rated Torque:**  
Cn is expressed in Nm and it corresponds to the rated power and rated rpm. It is given by the multiplication of the force for the arm (distance) and it is measured in Nm because the force is expressed in Newton and the distance in meters. The rated torque value is obtained by the formula  

$$C_n \text{ (Nm)} = 9550 \times [P_n / n]$$
 Pn = Rated Power in KW  
 N = Rated rotation speed in rpm

**Starting torque (or locked rotor torque):**  
Cs is the torque that the motor can develop with the rotor at a standstill and the rated power supply.

**Maximum torque (Pull out Torque):**  
Cmax is the maximum torque developed by the motor at the rated power supply at a certain speed.

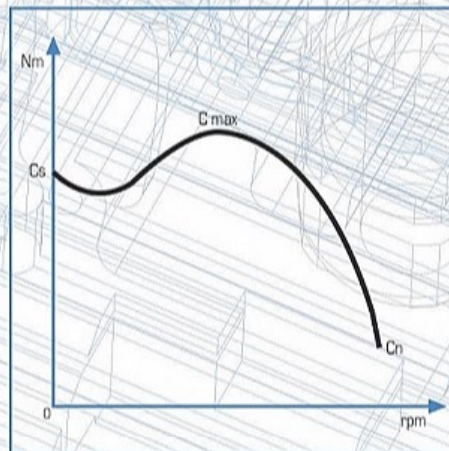

It represents also the value of the stall torque/pull out torque after which the motor stops.

In the following performance charts, it is indicated the relation between maximum torque and rated torque and maximum torque [Cmax / Cn]

**Efficiency:**  
η is expressed in % and it is given by the relation between the output power and the addition of output Power and the electric losses of the motor, that is the input power consumed by the motor. The electric motors losses are mainly of two kinds: copper losses and iron losses. These losses are lost in form of heat. Higher efficiency means energy savings, lower heating, longer life of insulating materials.

**Power factor or cos φ:**  
It represents the cosine of the voltage and current gap angle

**Noise:**  
The noise is expressed in dB (A). The measurement must be taken in accordance with the standard IS: 12065/ ISO 1680-2, in order to find the Sound Power level LwA measured at a distance of 1m from the machine. This standard describes the acoustic Power limits to be followed, indicating the maximum sound power level LwA. The noise values indicated in the performance charts that follow are for the motors operating in no-load condition, supplied at 50Hz and with a tolerance of +3 dB (A)

**The moment of inertia can be calculated in this way:**  

$$J = (1/2) \times M \times R^2$$
 Where M (Kg) is the mass which is rotated, while R (m) is the radius of the rotor/ rotating mass.

TOLERANCES

The data of each motor are specified in this catalogue like requested by the norm IS: 325. This describes in particular the following tolerance:

Characteristic	Tolerance
Efficiency (Output Power input Power)	-15% di (1- n)
Power factor	1/ 6 of [1- cos φ] min. 0.02 max 0.07
Locked rotor torque	-15% of the guaranteed torque +25% of the guaranteed torque
Maximum torque	-10% of the guaranteed torque, if torque is not less than 1.5- 1.6 the rated torque
Noise	+3dB(A)





## CUSTOM BUILT MOTOR

Rotomotive Design Engineers are well versed in the art & science of product / process design. They use tools like CAD/CAM extensively in their work. The analysis is complete well before the prototype is built. Manufacturing lines are well equipped & flexible. With the aid of a highly responsive Supply Chain team, lead times are significantly crashed while ensuring high quality & reliability.

Rotomotive offers motors for various applications in industries like wind energy, hydraulic power packs, electric transportation, construction, mining, HVAC blowers, cooling units and smoke evacuation system.

### Low Voltage Motors

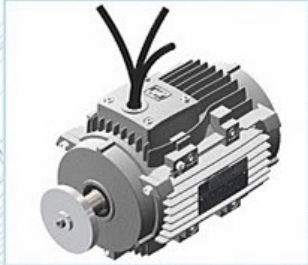

Material Handling System Motor



Hybrid Vehicles Motor

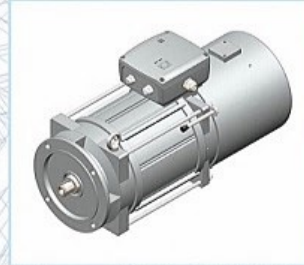

Tower Crane Hoist Motor



Overhead Crane Motor

### Crane Duty Motors

## HYDRAULIC PUMP MOTOR

Rotomotive has developed a whole range of hollow shaft motors, particularly for hydraulic pump application. This approach has significantly reduced the cost while at the same time improved efficiency. Final product is lighter & has reduced overall length.

### Salient Features :

- Eliminate the need for shaft coupling.
- Compact design
- Low moment of inertia.
- High efficiency
- Plug & Play
- Option of high pressure oil seals.



## SMOKE & HEAT EXHAUST VENTILATION MOTOR

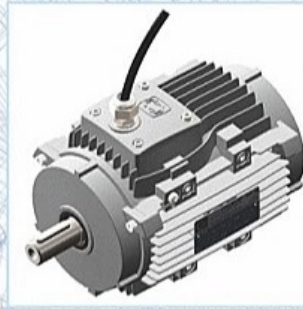

Delfire series of motors are designed to be a part of smoke and heat control ventilation systems. These systems create a smoke free layer above the floor by removing the smoke. Thus, they improve conditions for safe escape/rescue of people, animals and the protection of property. They also permit the fighting of fire while still in its early stage.

They are also used with jet fans to convey smoke, NOx, carbon monoxide and other gases from tunnels, car parks, basement areas and the likes. In many cases they operate in the hazard prevention mode. In case of fire outbreak, the temperature rises rapidly. Delfire motor work for a guaranteed period of 1 or 2 hours at a continuous temperature of 300, 250 & 200° Celsius, depending upon requirement. These can be single or two speed motors and are governed by the harmonized European standard EN12101.

## CE MARKING

CE marking is referred to:

- Community Low Voltage Directive (LVD) 73/23 EEC, modified by the Community Directive regarding marking 93/68 EEC
- Community Electromagnetic Compatibility Directive (EMC) 89/EEC and its modifications 91/263 336 EEC, 92/31 EEC e 93/68 EEC
- Community Machinery Directive (MD) 89/392 EEC and its modifications 91/368 EEC, 93/44 EEC e 93/68

CE marking is put by Rotomotive as a visible sign of the product compliance with the requirements of above mentioned directives. In order to reach this conformity, Rotomotive products respect the following product standards:

- EN 60034-1 (last issue). Rotating electrical machines. Part 1: rating and performance
- EN 60034-5 (last issue). Rotating electrical machines. Part 5: classification of degrees of protection
- EN 60034-6 (last issue). Rotating electrical machines. Part 6: methods of cooling (IC code)
- EN 60034-9 (last issue). Rotating electrical machines. Part 9: noise limits
- EN 50081-1 (last issue). Electromagnetic compatibility - Generic emission standard - Part 1: residential and light industry environment
- EN 50082-1 (last issue). Electromagnetic compatibility - Generic immunity standard - Part 1: residential and light industry environment
- EN 50081-2 (last issue). Electromagnetic compatibility - Generic emission standard - Part 2: Industrial environment
- EN 50082-2 (last issue). Electromagnetic compatibility - Generic immunity standard - Part 2: Industrial environment

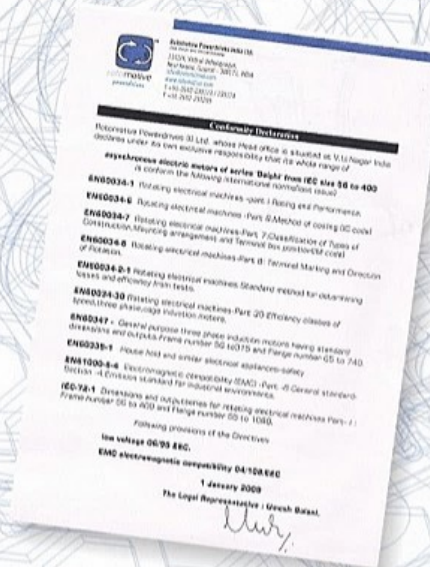

All information and data presented in this catalogue have been checked with greatest care. We however do not assume responsible for any unintended errors and omissions. Our designs are being continuously improved, so please reconfirm specifications and dimensions prior to ordering.

**Regional Sales Offices:**

**Rotomotive Ahmedabad**

Rotomotive Powerdrives India Ltd.  
Regional Office: Shridhar Bunglows  
No.14, Nr. Mansarover Tenement  
Nr. Arpan School, Nirang Cross Rd.  
PO. Vastral, Ahmedabad - 382 418  
Tel/Fax No: +91-79-29093837  
Cell No.: 093746 31145  
E-mail: sales.ahd@rotomotive.com

**Rotomotive Delhi**

Rotomotive Powerdrives India Ltd.  
212, 2<sup>nd</sup> Floor, Parmesh Business Center-II  
Plot no.23, Karkardooma Community Center  
Delhi-110092  
Tel. No.: +91-11- 47007139  
Cell No.: 093122 88326 / 093123 54230  
E-mail: sales.delhi@rotomotive.com

**Rotomotive Mumbai**

Rotomotive Powerdrives India Ltd.  
B-43 Station Plaza Commercial Complex  
Station Road, Bhandup (W), Mumbai - 400 078  
Tel. No.: +91-22- 67253048  
Cell No.: 093240 64643 / 093232 20023  
E-mail: sales.mum@rotomotive.com

**Rotomotive Secunderabad**

Rotomotive Powerdrives India Ltd.  
No 6013, VI Floor, Emerald House  
S.D. Road, Secunderabad - 500 003  
Cell No.: 093466 16807  
E-mail: sales.sec@rotomotive.com

**Rotomotive Bangalore**

Rotomotive Powerdrives India Ltd.  
Asha Chambers, F15, #2 (Old # 33)  
Venkataswamy Raju road, Kumarapark West  
Bangalore - 560020  
Tel:+91- 80 - 23465240/23465241  
Fax: +91 - 80 - 4147 9547  
Cell No.: 093437 04949 / 093421 61610  
E-mail: sales.blr@rotomotive.com

**Rotomotive Pune**

Rotomotive Powerdrives India Ltd.  
Plot No 425/77, T.M.V Colony,  
Opposite Katariya High School  
Gultekdi, Pune - 411037  
Cell No.: 087888 32719 / 090288 60832  
E-mail: sales.pune@rotomotive.com



**Rotomotive Powerdrives India Ltd.**

223, Napa Talpad,  
Gana-Borsad Road, Tal: Borsad, Anand  
Gujarat - 388 560, INDIA.  
Ph.: +91 - 92271 10030  
Fax: +91 - 2692 - 235209  
E-mail: info@rotomotive.com  
Web site: www.rotomotive.com

Authorised Dealer