



Digitized Automation for a Changing World

Delta Machine Vision System DMV Series



www.deltaww.com

 **DELTA**
Smarter. Greener. Together.

Delta Machine Vision System DMV Series

High Speed, High Precision, Smart and User-Friendly

The Delta Machine Vision System DMV Series is suitable for various automatic inspections on equipment or production lines, such as quality inspection, positioning guidance, identification, dimension measurement and others. As one of the best systems to facilitate smart manufacturing, Delta's DMV Series covers:

- **DMV1000G:** Features a user-friendly interface and requires no complicated settings. With built-in flash timer output control and a simultaneous dual-camera operation function, the DMV1000G greatly reduces the hardware development cost of vision detection systems.

The DMV1000G Series can quickly upload inspection data to PLCs and other host controllers via Ethernet, serial industrial network communication and I/O output, achieving quick integration with various automation systems.

- **DMV2000:** Matches with high-speed CameraLink cameras and various communication protocols, and can be rapidly integrated with external equipment. The DMV2000 supports multi-task inspection with up to four cameras to enhance efficiency and save development cost. As to program editing, the DMV2000 allows users to self-define the operation mode display / interface and offline mode functions to improve the utilization rate and flexibility.
- **DMV3000G:** Provides a smart and user-friendly operation interface and adopts GigE cameras to achieve higher transmission speed. The DMV3000G retains the outstanding features of the DMV1000 and DMV2000, and provides a better user experience in different applications.

With its advanced vision inspection tools, the DMV Series enhances overall automation production efficiency and product quality for various industries, including machinery, automotive, rubber and plastics, pharmaceuticals, food & beverage, printing, packaging, metal processing, robotic arm integration applications, TFT, semiconductor, solar energy and other electronics industries.

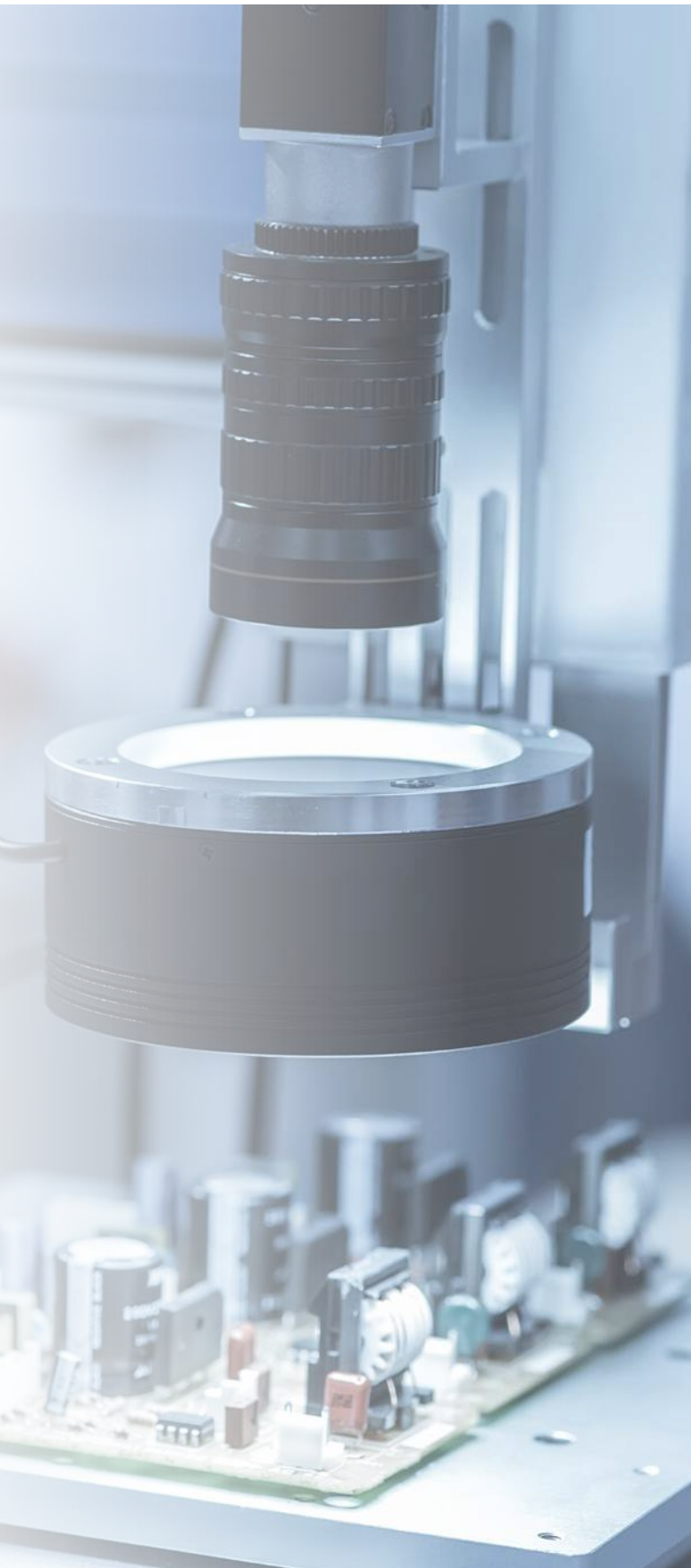

Table of Contents

System Configuration	4
Features:	
DMV3000G	5
DMV2000	6
DMV1000G	7
Applications	8
Specifications	12
Product Parts	15
Dimensions	24
Ordering Information	30
Global Operations	34

System Configuration



Major Applications of Machine Vision Systems



Quality Inspection
Object and defect inspection



Positioning & Guidance
Cross center positioning, edge positioning, and guidance



Measurement & Counting
Dimension measurement, package/product counting



Identification
1D/2D barcode and character identification

Features - DMV3000G

Supports up to 2 GigE high-speed mono/color cameras, and transmits/outputs inspection data to other devices via Ethernet, R-232/485, and I/O

- Supports 2 color/monochrome GigE industrial cameras for simultaneous multi-task detection
- Smart and easy setup allows quick project creation
- Enhanced inspection speed to increase production efficiency and save cost
- Multiple built-in image inspection tools, saving the time needed for programming

Appearance

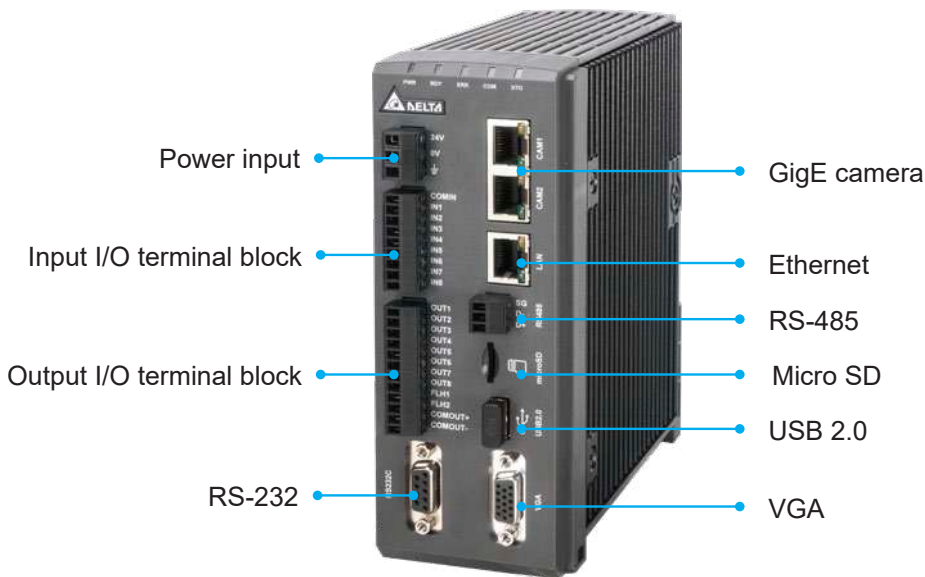

Camera Specifications

Resolution	Chroma	Frame Rate	Pixel Dimensions (Horizontal x Vertical)	Sensor Size (mm) (Horizontal x Vertical)	Pixel Size (µm)	Lens Mount
0.3 M	Mono/Color	180 fps	640×480	1/3.6" (3×2.3)	4.8	C mount
2 M	Mono/Color	50 fps	1600×1200	1/1.8" (7.5×5.6)	4.7	C mount

Applications

Inspection for mobile phone lens quality, disposable coffee filters, and others on automated production lines in logistics, food and beverage packaging, electronics, printing industries and more



Features - DMV2000

Supports up to 4 color/mono CameraLink cameras to facilitate fast data transmission for high-speed inspection

- Improves efficiency and saves development cost: Simultaneous multi-task inspection with 4 cameras
- Reduces development and setup time: Smart operation process, user-friendly interface, multi-function vision development tools, PLC communication function for automatic data exchange
- Flexible configuration: Self-defined operation interface and display
- Multiple communication protocols: Quick connection with external devices
- Fast, stable image capture and transmission: Supports color/monochrome CameraLink cameras (0.3M~12M)

Appearance

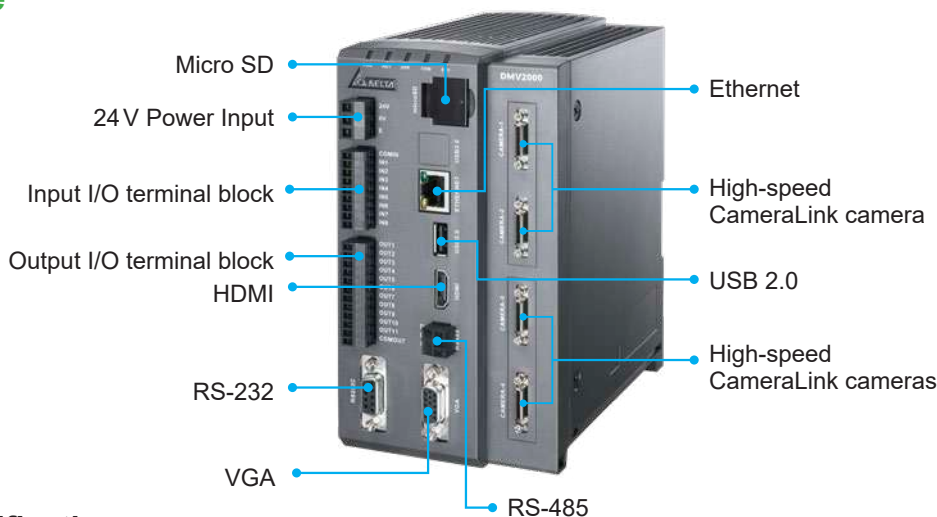

Camera Specifications

Resolution	Chroma	Frame Rate	Pixel Dimensions (Horizontal x Vertical)	Sensor Size (mm) (Horizontal x Vertical)	Pixel Size (μm)	Lens Mount
0.3M	Mono / Color	432 fps	640×480	1/3" (4.8×3.6)	7.4	C mount
2M	Mono / Color	333 fps	2048×1088	2/3" (11.26×5.98)	5.5	C mount
4M	Mono / Color	180 fps	2048×2048	1" (11.26×11.26)	5.5	C mount
5M	Mono / Color	35 fps	2448×2058	2/3" (8.4×7.0)	3.45	C mount

Applications

Automated production lines, industrial robots, vision guided robotic system (VGRS) and more in food and beverage packaging, electronics, printing and pharmaceutical industries



Features - DMV1000G

Basic machine vision system that supports up to 2 GigE mono cameras

- Programs, parameters, inspection images and results recorded and stored in SD cards
- Easy settings and operation with a joystick
- Provides a variety of digital I/O connections, a 9-pin input cord end terminal, a 9-pin output interface terminal, and a 50-pin input/output terminal
- Built-in vision inspection function development tools, no need for complex program editing
- Higher system reliability, better than PC-Based systems
- Compact design saves installation space

Appearance

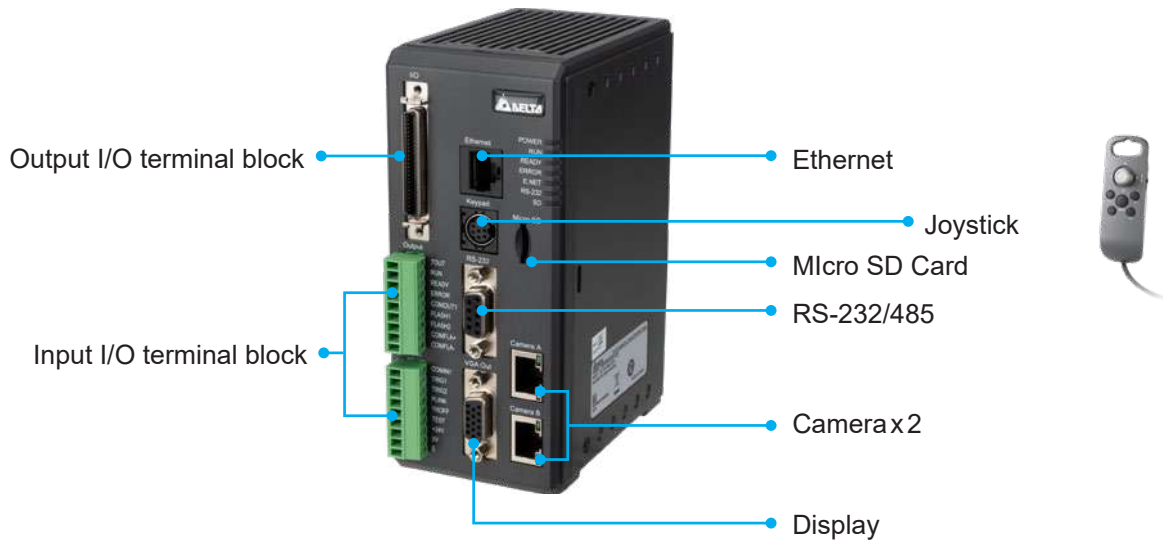

Camera Specifications

Resolution	Chroma	Frame Rate	Pixel Dimensions (Horizontal x Vertical)	Sensor Size (mm) (Horizontal x Vertical)	Pixel Size (µm)	Lens Mount
0.3 M	Mono	120 fps	640 × 480	1/2.9" (4.9 x 3.7)	7.76	C mount
0.8 M	Mono	60 fps	1024 × 768	1/2.9" (4.9 x 3.7)	4.85	C mount

Applications

Automated production lines, industrial robots, vision guided robotic system (VGRS) and more in food and beverage packaging, electronics, printing and pharmaceutical industries



Applications

01 Quality Control

Object and Defect Inspection

Object Inspection

Inspects product appearance such as buttons and touchscreens

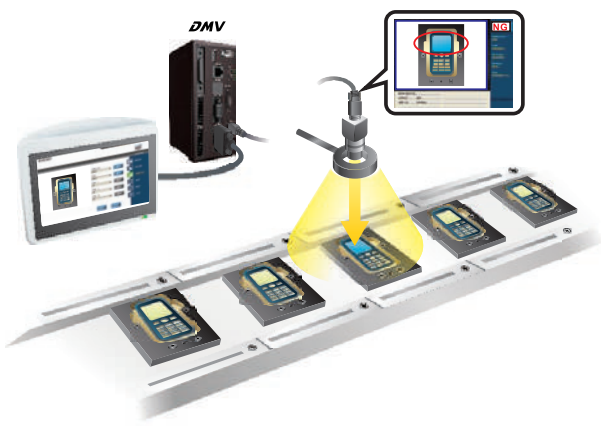

Label Inspection

Inspects stains or damage on labels

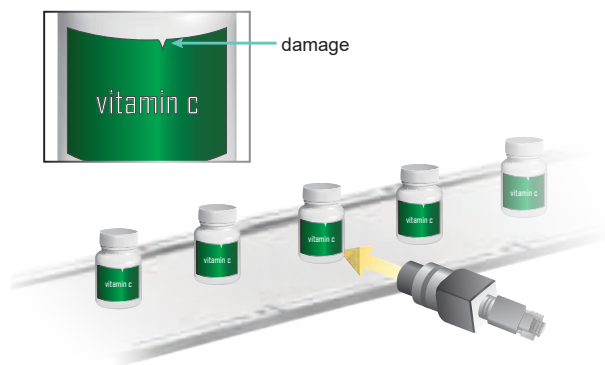

Direction Identification

Inspects the direction of workpieces conveyed on a production line

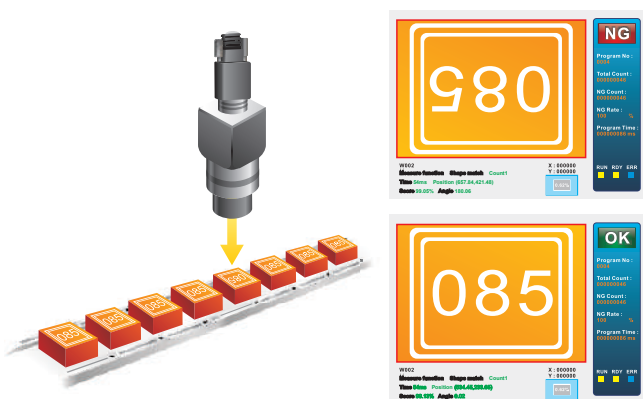

Printing Quality Inspection

Inspects pictures or graphs printed on paper or workpieces to ensure quality



02 Positioning & Guidance

Cross Center Positioning, Edge Positioning, Guidance

Pick-and-Place Robot Guidance

Vision guidance for industrial robots to precisely perform workpiece pick-and-place

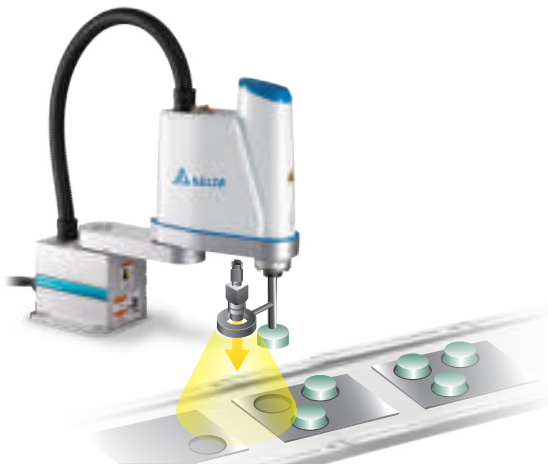

Beverage Packing Inspection

Inspects the liquid level of each bottle

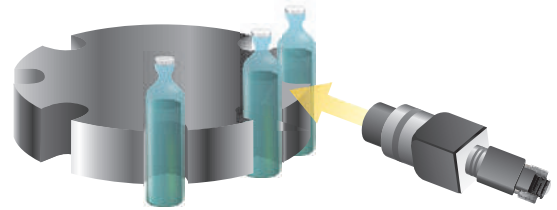
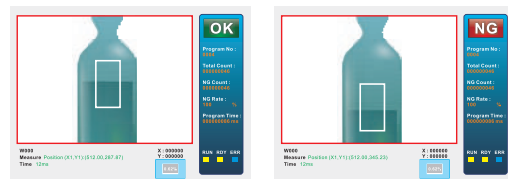

Defect Detection

Automatic positioning of PCBs and TFT boards

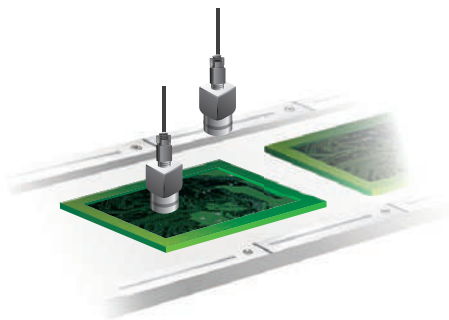
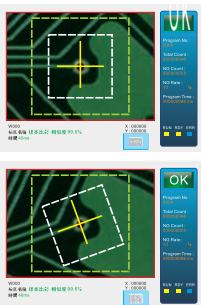

Bottle Cap Position Identification

Identifies the bottle capping position

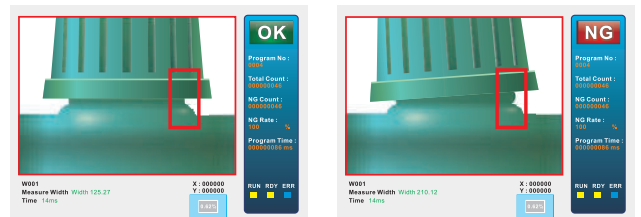

Applications

03 Measurement & Counting

Object Counting

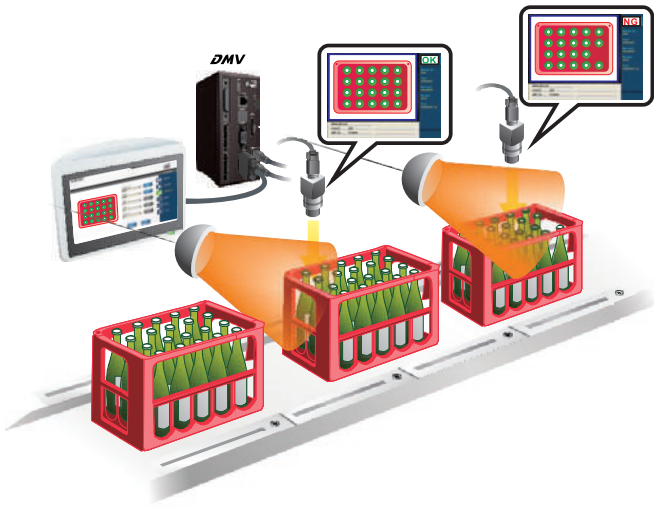

Dimensions Measurement

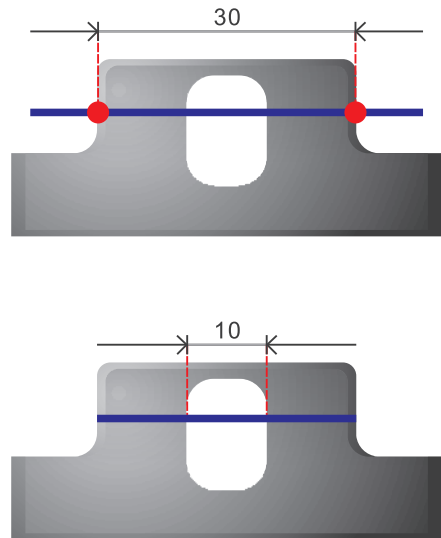

Bearing Ball Counting

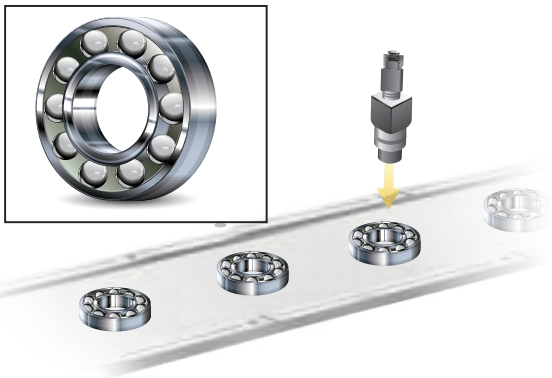

Pin Number Counting

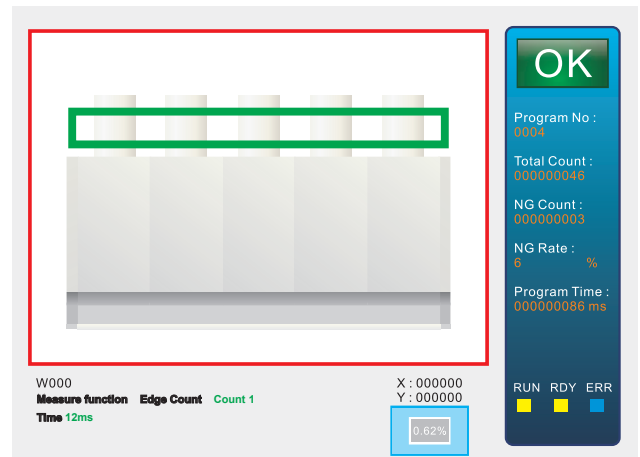

04 Identification

Optical Character Verification (OCV)

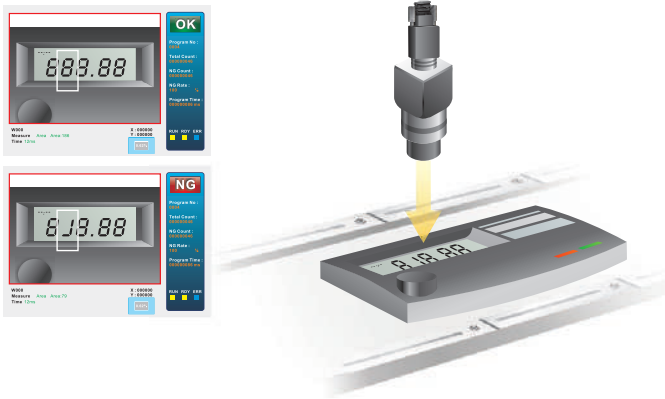

Production / Expiration Date Inspection

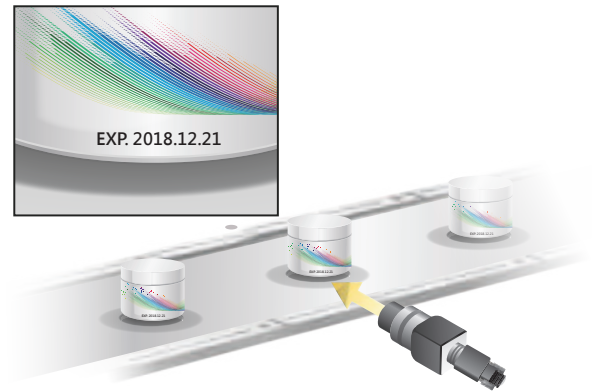

Barcode Identification



Material Printing Correctness Identification

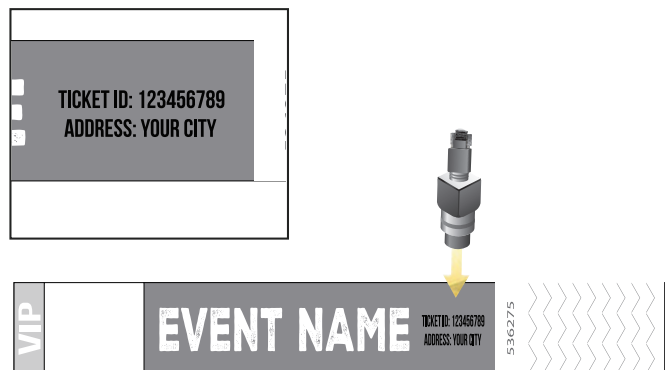

Specifications

Specifications	DMV3000G	DMV2000	DMV1000G
Controllers			
Power Supply	24 V _{DC}	24 V _{DC}	24 V _{DC}
Operation Voltage Range	Rated Voltage 90% ~ 110%	Rated Voltage 90 % ~ 110 %	Rated Voltage 90 % ~ 110 %
Current Consumption	2 camera: below 2.5 A	4 cameras: below 4 A 2 camera: below 3.4 A	2 cameras: below 1 A
Vibration Resistance	5~8.4 Hz/3.5 mm and 8.5~150 Hz/1 G for 1 hr; XYZ axes	<ul style="list-style-type: none"> No error: XYZ axes / 10~55 Hz/ 10 m/s² (1.0 G) for 10 mins No damage: XYZ axes / 10~55 Hz/ 20 m/s² (2.0 G) for 2 hrs 	10~55 Hz 10 m/s for 10 mins; XYZ axes
Shock Resistance	Max. 15 G XYZ axes/6 directions, 3 times each	<ul style="list-style-type: none"> No error: 200 m/s² (20 G), 6-surface/3-edge/1-corner, 3 drops each No damage: 300 m/s² (30 G), 6-surface/3-edge/1-corner, 3 drops each 	Max. 300 m/s XYZ axes/6 directions, 3 times each
Ambient Operating Temperature	-10°C ~ 50°C	0°C ~ 45°C	0°C ~ 50°C
Storage Temperature	-30°C ~ 85°C	-20°C ~ 65°C	-20°C ~ 65°C
Operating Relative Humidity	35% ~ 65% RH (non-condensing)	35% ~ 85% RH (with no icing or condensation)	35% ~ 65% RH (non-condensing)
Altitude	Under 2000 m	Under 2000 m	Under 2000 m
Cameras			
Type	Digital color/mono GigE camera	Digital color/mono CameraLink camera	GigE digital mono camera
Resolution	<ul style="list-style-type: none"> 0.3M: 640 (H)x480 (V), Base: 180 fps 2M: 1600 (H)x 1200 (V), Base: 50 fps 	<ul style="list-style-type: none"> 0.3M: 640 (H)x484 (V), Base: 432 fps 2M: 2048 (H)x1088 (V), Base: 74 fps, Full: 333 fps 4M: 2048 (H)x2048 (V), Base: 40 fps, Full: 180 fps 5M: 2448 (H)x2048 (V), Base: 32 fps, Full: 35 fps 	<ul style="list-style-type: none"> 0.3M: 640 (H)x480 (V), Base: 120 fps 0.8M: 1024 (H) x 768 (V), Base: 60 fps
Shutter Speed	17 μs ~ 1.8 s	25 μs ~ 16.7 s	0.05 ms ~ 1 s or user-defined (16 kinds of speeds)
Lens Mount	C mount	C mount/F mount	C mount
Ambient Operating Temperature	0°C ~ 45°C	0°C ~ 45°C	0°C ~ 45°C
Storage Temperature	-20°C ~ 85°C	-20°C ~ 65°C	-30°C ~ 60°C
Weight	Approx. 50 g	Approx. 140 g	Approx. 58 g

Specifications	DMV3000G	DMV2000	DMV1000G
Functions			
Number of Cameras Connectable	Max. 2	DMV2000-CL4-HS: Max. 4 DMV2000-CL2-HS: Max. 2	Max. 2
Number of Projects	<ul style="list-style-type: none"> Internal memory: capacity varies according to projects / up to 1,000 Memory card: capacity varies according to projects / up to 9,999 Supports changeover by I/O and communication (RS-232, RS-485, Ethernet) 	<ul style="list-style-type: none"> Internal memory: Approx. 6,000 projects SD card: no capacity limit Supports changeover by I/O and communication (RS-232, RS-485, Ethernet) 	<ul style="list-style-type: none"> 32 projects in internal memory 68 projects in SD Card Supports changeover by I/O and communication
Inspection Window			
Q'ty	Max. 128 screens per process Max. 2 processes per project	Max. 1,000 screens per project	Max. 128 screens per project
ROI Type	Rectangle, circle, polygon, ellipse, ring, sector, rotated rectangle	Rectangle, circle, polygon, ellipse, ring, sector, rotated rectangle	Rectangle, circle, polygon, ellipse, ring, sector, rotated rectangle
Mask Area	8 areas/window	8 areas/window	4 areas/window
Type	Rectangle, circle, polygon, ellipse, ring, sector, rotated rectangle	Rectangle, circle, polygon, ellipse, ring, sector, rotated rectangle	Rectangle, circle, polygon, ellipse, ring, sector, rotated rectangle
Execution Mode	Always execute, never execute, execute according to references	Always execute, never execute	Always execute, never execute, execute according to references
Inspection Units			
Shape	O	O	O
Edge Angle	O	O	O
Edge Count	O	O	O
Edge Pitch	O	O	O
Edge Position	O	O	O
Edge Width	O	O	O
Area	O	O	O
Blob	O	O	O
Intensity	O	O	O
Position Trace	O	O	O
Width Trace	O	O	O
Stain	O	O	O
OCV	O	O	O
Comparison	X	O	X
Color	O	O	X
1D Barcode	O	O	O
2D Barcode	O	O	O
Sorting	X	X	O
Mark	O	X	O
1P Position	X	O	X
Blob Matching	X	O	X
Auto-calibration	O	X	X
Dual-camera Alignment Stage	O	X	O

Specifications

Specifications	DMV3000G	DMV2000	DMV1000G
Image Pre-process			
Binarization	O	O	O
Expansion	O	O	O
Erosion	O	O	O
Average	O	O	O
Median	O	O	O
Crispening	O	O	O
Laplacian	O	O	O
Sobel X	O	O	O
Sobel Y	O	O	O
Sobel	O	O	O
Prewitt	X	X	O
Roberts	X	X	O
Difference	O	O	O
Color Extraction	O	O	X
Brightness Adjustment	O	O	X
Contrast Enhancement	O	O	X
Shadow Compensation	O	O	X
Top Hat	X	O	X
Bottom Hat	X	O	X
Self-defined Filter	O	O	X
Grayscale Filling	O	X	X
Numerical Calculation			
Q'ty	Max. 1,024/Project	Max. 1,000/Project	32
Arithmetic	Plus, Subtract, Multiply, Divide	Plus, Subtract, Multiply, Divide	Plus, Subtract, Multiply, Divide
Communication Protocols	Configurable input pins: 8 Configurable output pins: 11 RS-232 (max. 230,400 bps) RS-485 (max. 230,400 bps) Ethernet (10/100/1000 BASE-T)	Configurable input pins: 8 Configurable output pins: 11 RS-232 (max. 115,200 bps) RS-485 (max. 230,400 bps) Ethernet (1000 BASE-T/100 BASE-TX/10 BASE-T)	RS-232 (max. 115,200 bps) RS-485 (max. 115,200 bps) Ethernet (10/100BASE-T)
Display			
Screen	XGA 1,024×768 output	FHD 1,920×1,080 output	XGA 1,024×768 output
Scale	5%~800% adjustable	5%~1,000% adjustable	20%~200% adjustable
Language	Traditional Chinese, Simplified Chinese, English	Traditional Chinese, English	Traditional Chinese, Simplified Chinese, English
Operation Interface			
Operation	Mouse (standard 3 keys)	Mouse (standard 3 keys)	Joystick
Camera Flash Control	Up to 2 sets of I/O output control configurations	Up to 2 sets of I/O output control configurations	I/O output control, max. 2 settings
Memory Card	Micro SD card (max. 32 GB); Class 10	Micro SD card (max. 32 GB); Class 10	Micro SC card (max. 16 GB)

Product Parts - DMV3000G

Controller

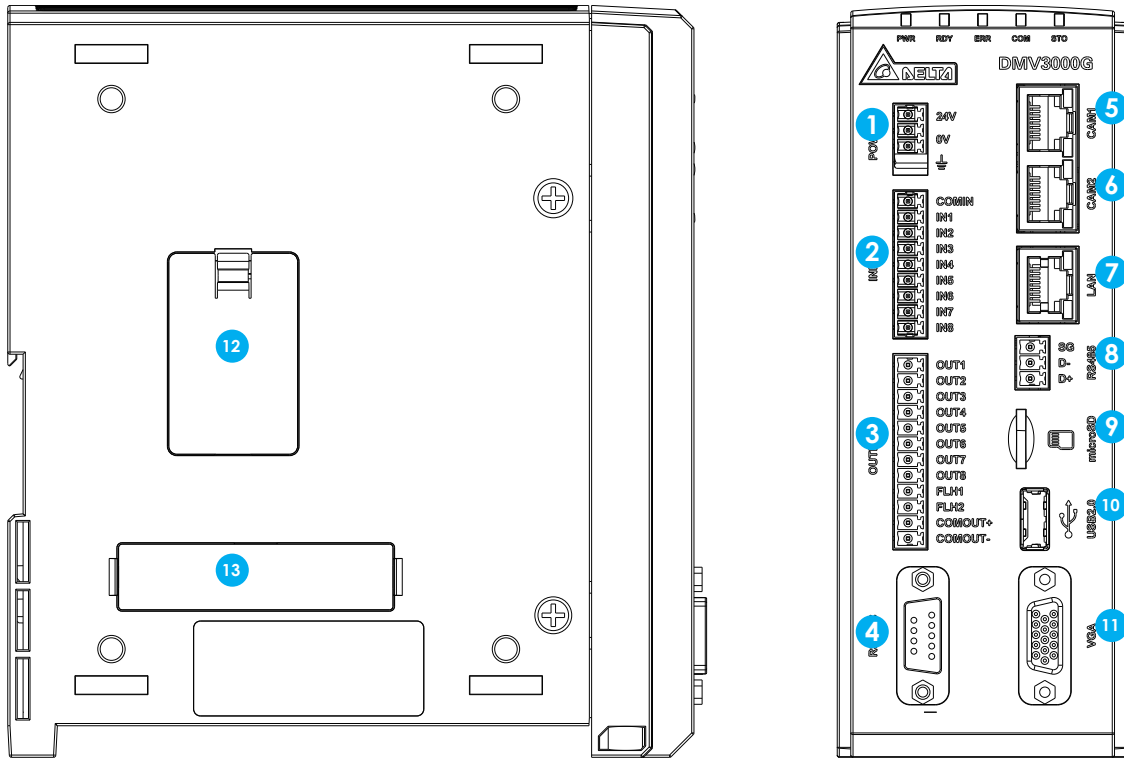

No.	Name	Description
1	Power supply	24 V Power input
2	Input I/O terminal block	Input terminal (9-pin)
3	Output I/O terminal block	Output terminal (12-pin)
4	RS-232 serial port	Supports master/slave serial communication
5	Camera 1 connector	GigE camera connection
6	Camera 2 connector	GigE camera connection
7	Ethernet connector	10/100/1000 BASE-T communication
8	RS-485 serial port	Supports master/slave serial communication
9	Micro SD card slot	Stores backups of project settings and images
10	USB 2.0 connector	Mouse
11	VGA output port	Connects to external VGA monitor
12	Button cell battery slot	Power supply for perpetual calendar operation
13	Expansion module slot	Flash control, expanded I/O

Product Parts - DMV3000G

9-Pin Input Terminals

No.	Name	Description
1	COMIN	9-pin input COM
2	TRIG1	Camera 1 capture trigger
3	TRIG2	Camera 2 capture trigger
4	TROFF	Trigger disabled (inspection disabled)
5	FCH	I/O project switching trigger
6	FIN1	I/O project switching option b0
7	FIN2	I/O project switching option b1
8	FIN3	I/O project switching option b2
9	FIN4	I/O project switching option b3

Default Setting

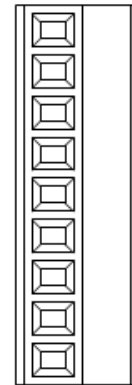

- 1 - COMIN
- 2 - IN1 (TRG1)
- 3 - IN2 (TRG2)
- 4 - IN3 (TROFF)
- 5 - IN4 (FCH)
- 6 - IN5 (FIN1)
- 7 - IN6 (FIN2)
- 8 - IN7 (FIN3)
- 9 - IN8 (FIN4)

12-Pin Output Terminals

No.	Name	Description
1	READY1	Controller ready output indicator 1
2	READY2	Controller ready output indicator 2
3	RUN	Run status indicator
4	ERR	Error status indicator
5	TOUT1	Result output 1
6	TOUT2	Result output 2
7	TOUT3	Result output 3
8	TOUT4	Result output 4
9	FLH1	Camera 1 light source strobe control output
10	FLH2	Camera 2 light source strobe control output
11	COMOUT+	Output common contact. Connect to the positive terminal of the power source
12	COMOUT-	Output common contact. Connect to the negative terminal of the power source

Default Setting

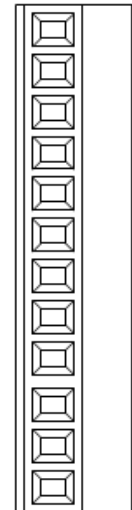

- 1 - OUT1 (READY1)
- 2 - OUT2 (READY2)
- 3 - OUT3 (RUN)
- 4 - OUT4 (ERR)
- 5 - OUT5 (TOUT1)
- 6 - OUT6 (TOUT2)
- 7 - OUT7 (TOUT3)
- 8 - OUT8 (TOUT4)
- 9 - FLH1
- 10 - FLH2
- 11 - COMOUT+
- 12 - COMOUT-

Input Circuit (NPN Input)

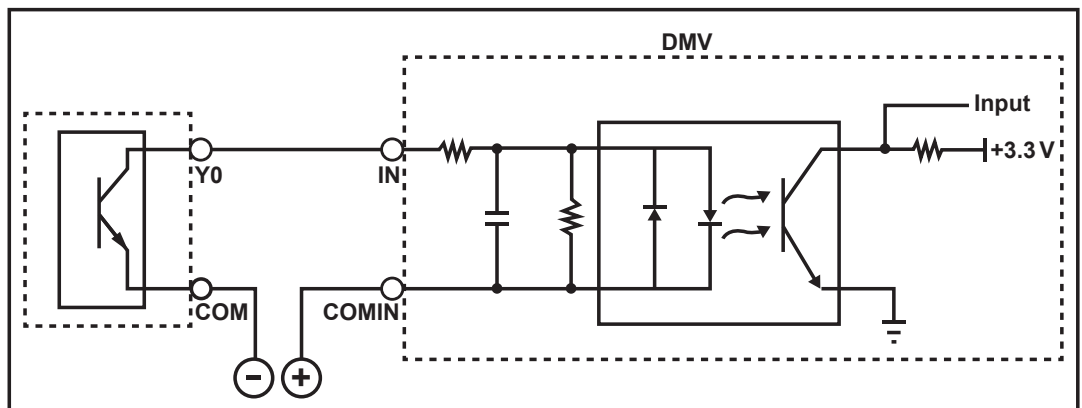

Input Circuit (PNP Input)

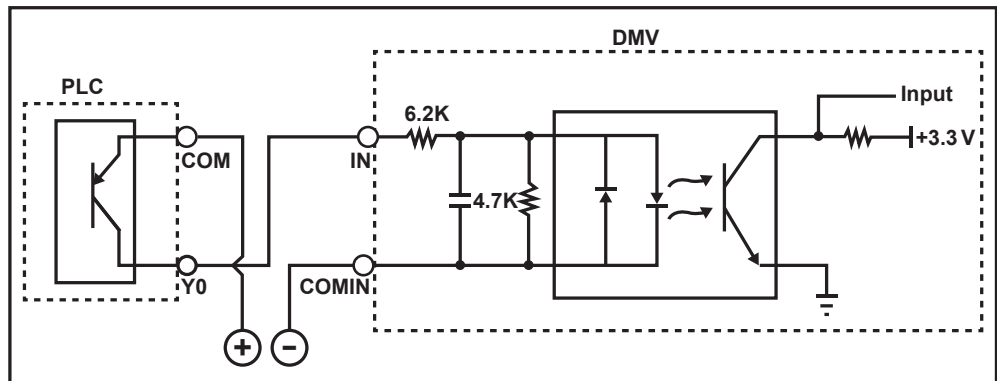

Output Circuit (NPN Output)

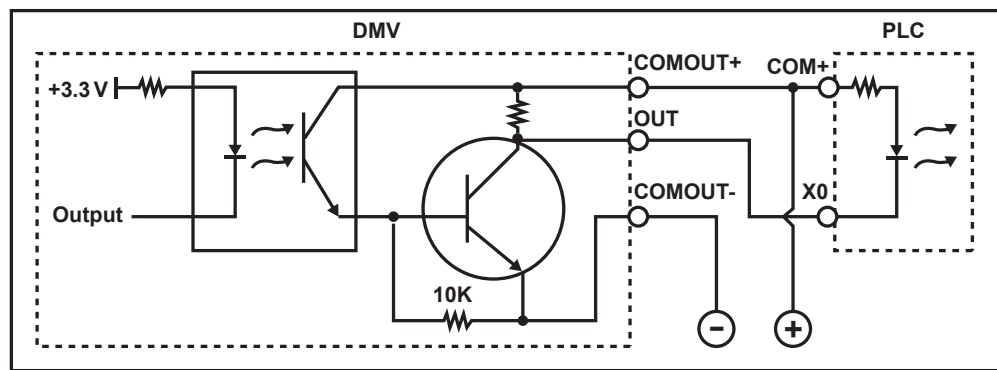

Output Circuit (PNP Output)

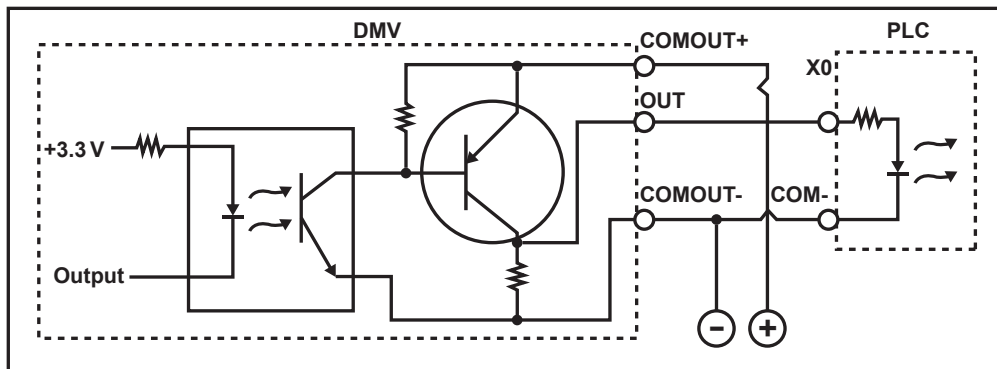

FLASH Output

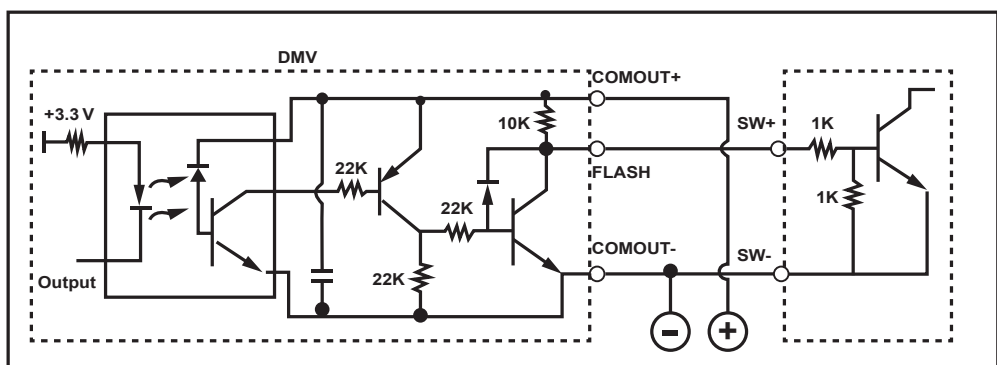

Product Parts - DMV2000

Controller

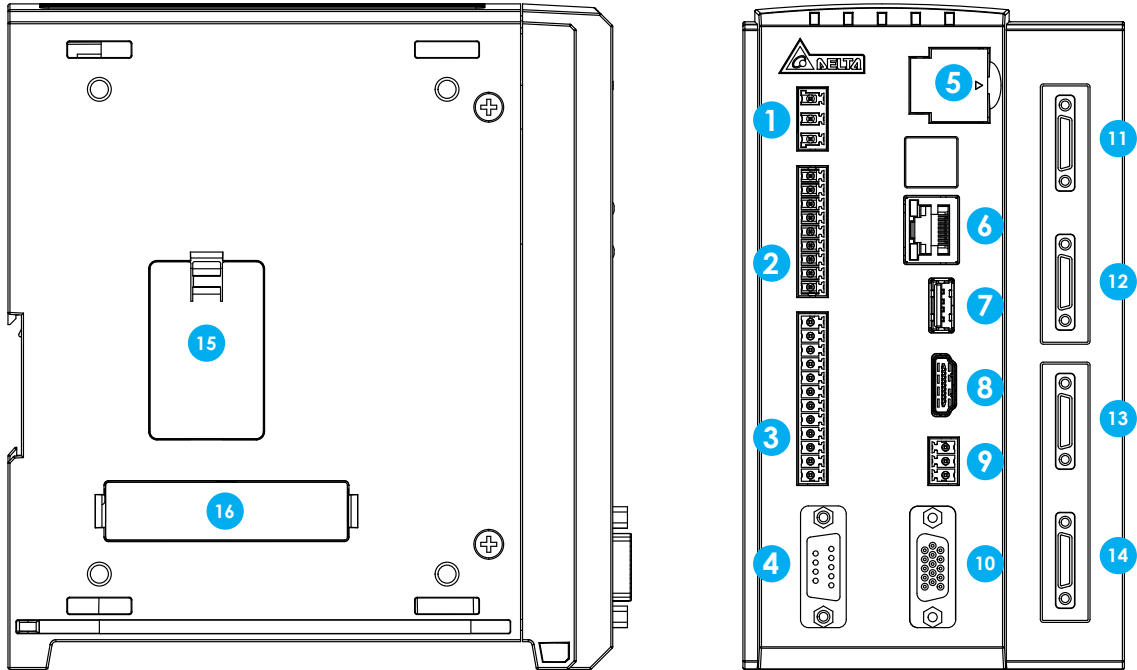

NO.	Name	Description
1	Power input terminal block	24 V power input
2	Input I/O terminal block	Input terminal (9-pin)
3	Output I/O terminal block	Output terminal (12-pin)
4	RS-232 serial port	Supports master/slave serial communication
5	Micro SD card slot	Stores backups of project settings and images
6	Ethernet connector	10/100/1000 BASE-T communication
7	USB 2.0 connector	Mouse
8	HDMI output port	Connects to external HDMI monitor (Resolution: 1,920 x 1,080)
9	RS-485 serial port	Supports master/slave serial communication
10	VGA output port	Connects to external VGA monitor (Resolution: 1,920 x 1,080)
11	Camera 1 connector	Resolution: 0.3M, 2M, 4M, 5M camera
12	Camera 2 connector	Resolution: 0.3M, 2M, 4M, 5M camera
13	Camera 3 connector	Resolution: 0.3M, 2M, 4M, 5M camera
14	Camera 4 connector	Resolution: 0.3M, 2M, 4M, 5M camera
15	Button cell battery slot	Power supply for perpetual calendar operation
16	Expansion module slot	Camera flash control, expanded I/O

3-Pin Power Terminal

NO.	Name	Description
1	+24V	Positive power supply
2	0V	Negative power supply
3	E	Grounding

Default Setting

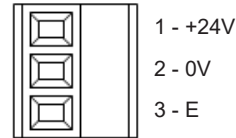

9-Pin Power Terminal

NO.	Name	Description
1	COMIN	9-pin input COM
2	IN1 (TRG1)	Camera 1 image capture trigger
3	IN2 (TRG2)	Camera 2 image capture trigger
4	IN3 (TRG3)	Camera 3 image capture trigger
5	IN4 (TRG4)	Camera 4 image capture trigger
6	IN5 (TEST)	Test condition (no data output)
7	IN6 (PLINK)	PLC communication link start sign
8	IN7 (TROFF)	Disable image capture trigger
9	IN8 (ACK)	Controller parallel input handshaking sign

Default Setting

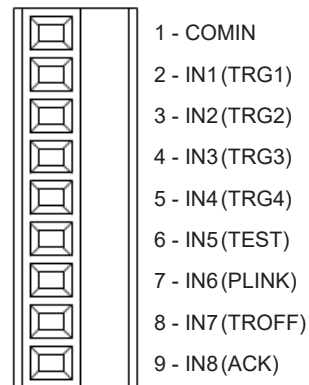

12-Pin Output

NO.	Name	Description
1	OUT1	Controller standby for image capture and inspection output
2	OUT2	Judgement Result Output 1
3	OUT3	Judgement Result Output 2
4	OUT4	Error indicator
5	OUT5	Parallel output handshake flag
6	OUT6	Camera 1 capture complete
7	OUT7	Camera 2 capture complete
8	OUT8	Camera 3 capture complete
9	FLH1	Camera 2 flash output
10	FLH2	Camera 2 flash output
11	COMOUT+	Common output port (Please connect to a positive power supply)
12	COMOUT-	Common output port, (Please connect to a negative power supply)

Default Setting

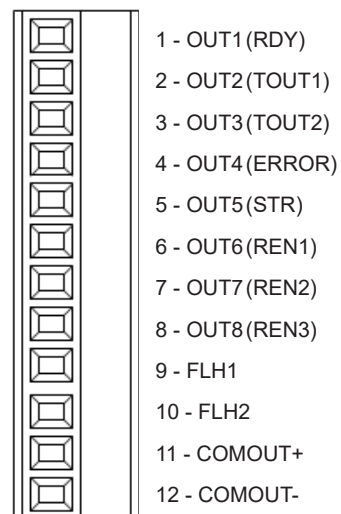

Product Parts - DMV2000

Input Circuit (NPN Input)

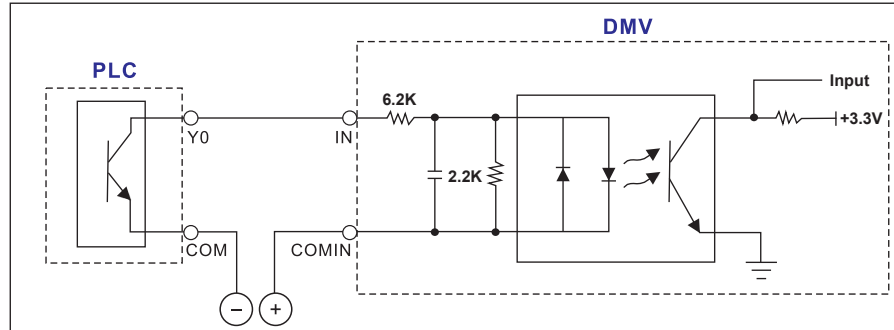

Input Circuit (PNP Input)

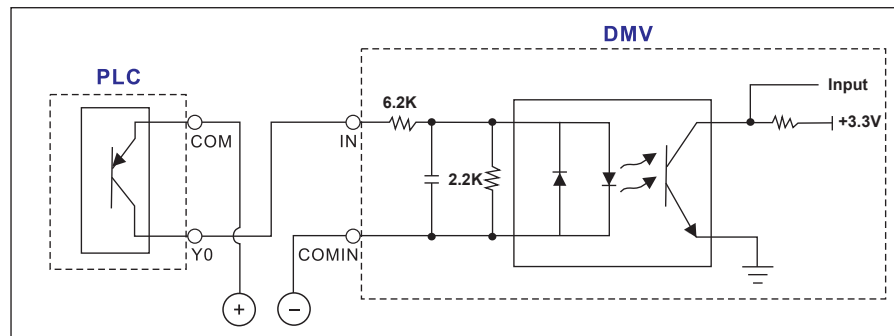

Output Circuit (NPN Output)

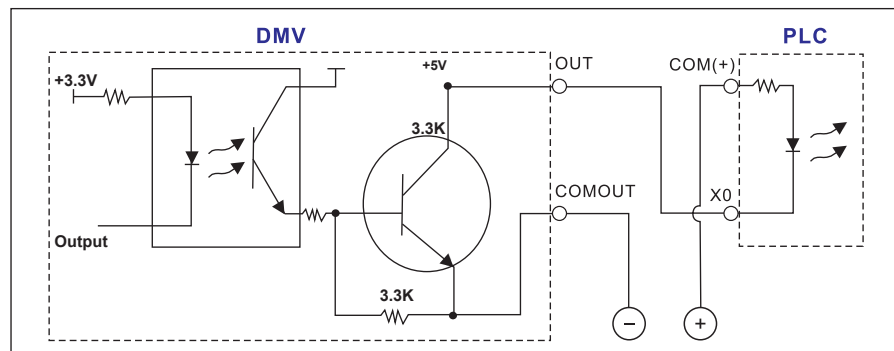

FLASH Output

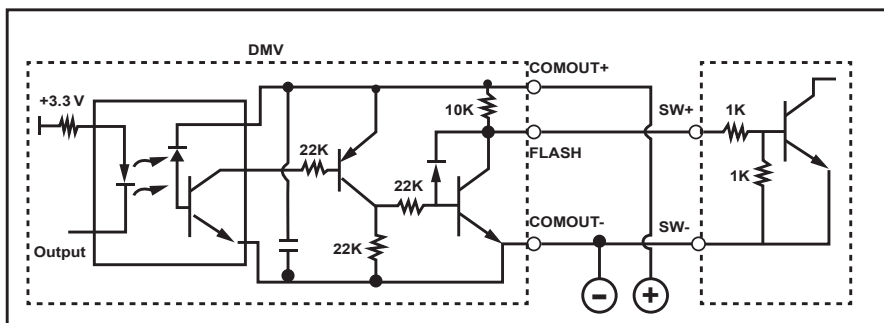

Product Parts - DMV1000G

Controller

NO.	Name	Description
1	Parallel I/O interface	Input/Output
2	Output I/O terminal block	Output
3	Input I/O terminal block	Input
4	Ethernet connector	10/100BASE-T communication
5	Keypad connector	Connect to keypad
6	RS-232/RS-485 serial port	Supports master/slave serial communication
7	VGA output port	Connects to external VGA monitor
8	Micro SD memory card	Stores backups of project settings and images
9	Camera 1 connector	Resolution: 1024×768, 640×480
10	Camera 2 connector	Resolution: 1024×768, 640×480

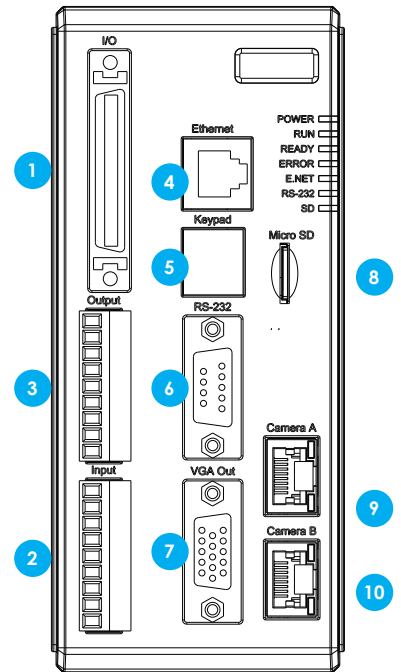

Joystick

NO.	Name	Description
1	Move and Enter	8 directions selectable and enter setting
2	PROG/RUN	Switches between programming mode and run mode
3	TRIG	Inspection trigger
4	FUNC	Selects different modes during RUN operation
5	DISPLAY	Switches inspection windows of camera 1 and camera 2
6	CUSTOM	Image preprocessing select
7	ESCAPE	Exit key

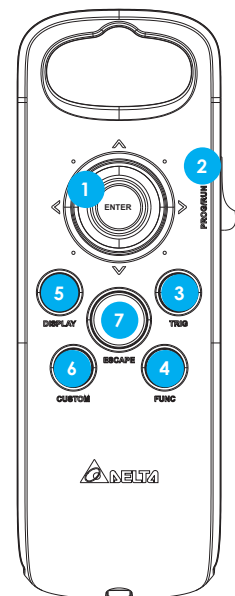

Product Parts - DMV1000G

9-Pin Input Terminals

NO.	Name	Description
1	COMIN1	9-pin input COM
2	TRIG1	Camera 1 image capture trigger
3	TRIG2	Camera 2 image capture trigger
4	PLINK	PLC communication link start sign
5	TROFF	Disable image capture trigger
6	TEST	Test condition (no data output)
7	+24V	Positive power supply
8	0V	Negative power supply
9	E	Grounding

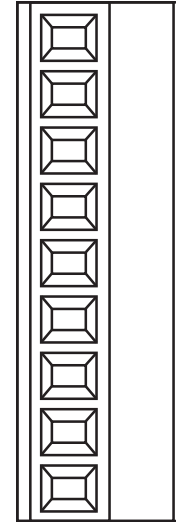

- 1-COMIN1
- 2-TRIG1
- 3-TRIG2
- 4-PLINK
- 5-TROFF
- 6-TEST
- 7-+24V
- 8-0V
- 9-E

9-Pin Output Terminals

NO.	Name	Description
1	TOUT	Overall inspection result output
2	RUN (TOUT2)	Operation status indicator (Overall inspection result output 2)
3	READY	Controller ready for image inspection result output
4	ERROR	Error(s) occur(s)
5	COMOUT1	Common 9-pin output port
6	FLASH1	Camera 1 flash output
7	FLASH2	Camera 2 flash output
8	COMFLA+	Common output port (Please connect to a positive power supply)
9	COMFLA-	Common output port (Please connect to a negative power supply)

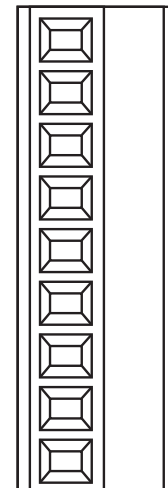

- 1-TOUT
- 2-RUN (TOUT2)
- 3-READY
- 4-ERROR
- 5-COMOUT1
- 6-FLASH1
- 7-FLASH2
- 8-COMFLA+
- 9-COMFLA -

Input Circuit
(NPN Input)

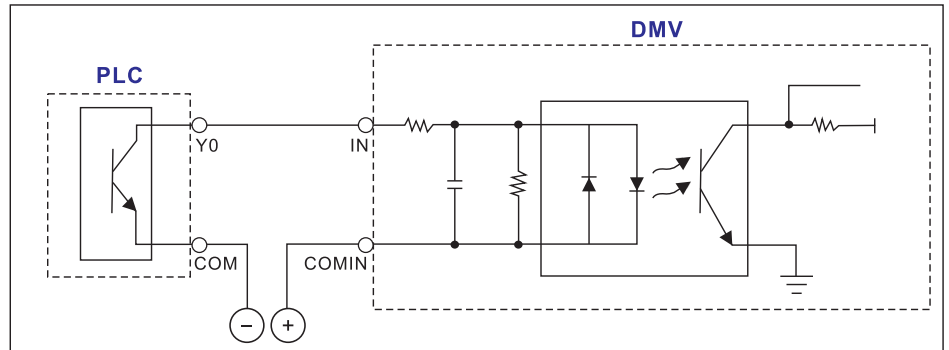

Input Circuit
(PNP Input)

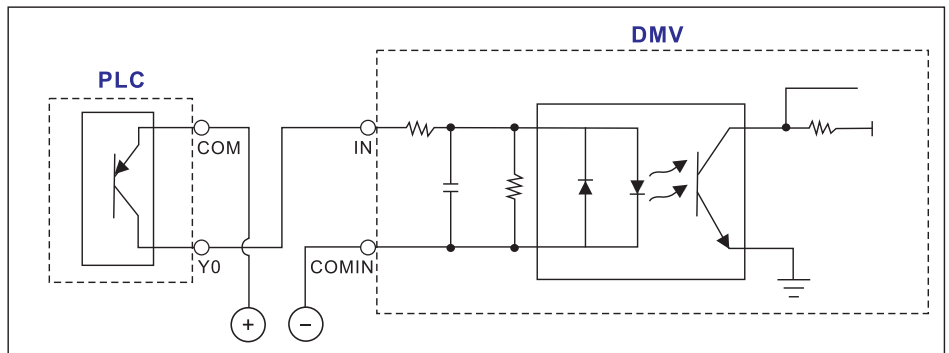

Output Circuit
(NPN Output)
(FLASH 1 and
FLASH 2 Excluded)

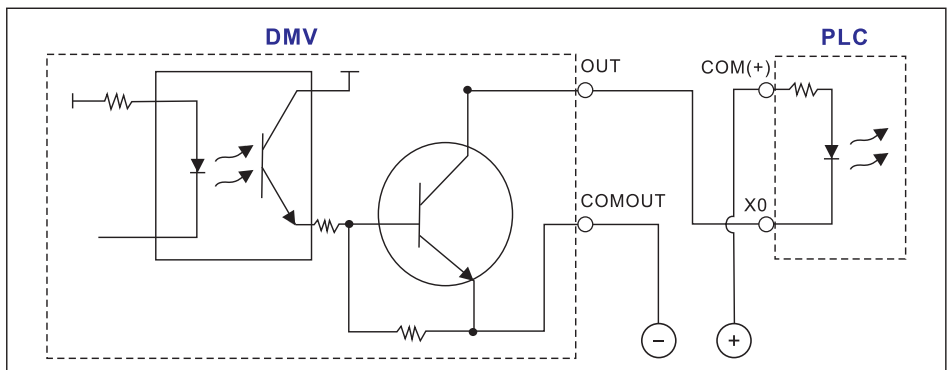

**FLASH 1 & 2
Output Circuit**

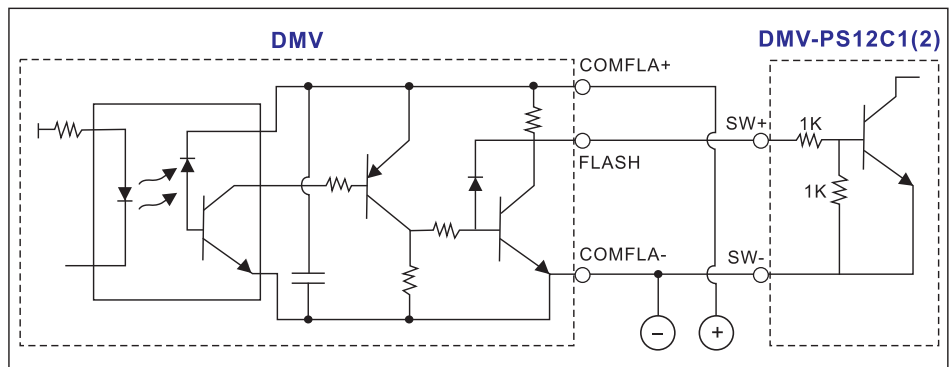

Dimensions

DMV3000G Controller

Unit: mm

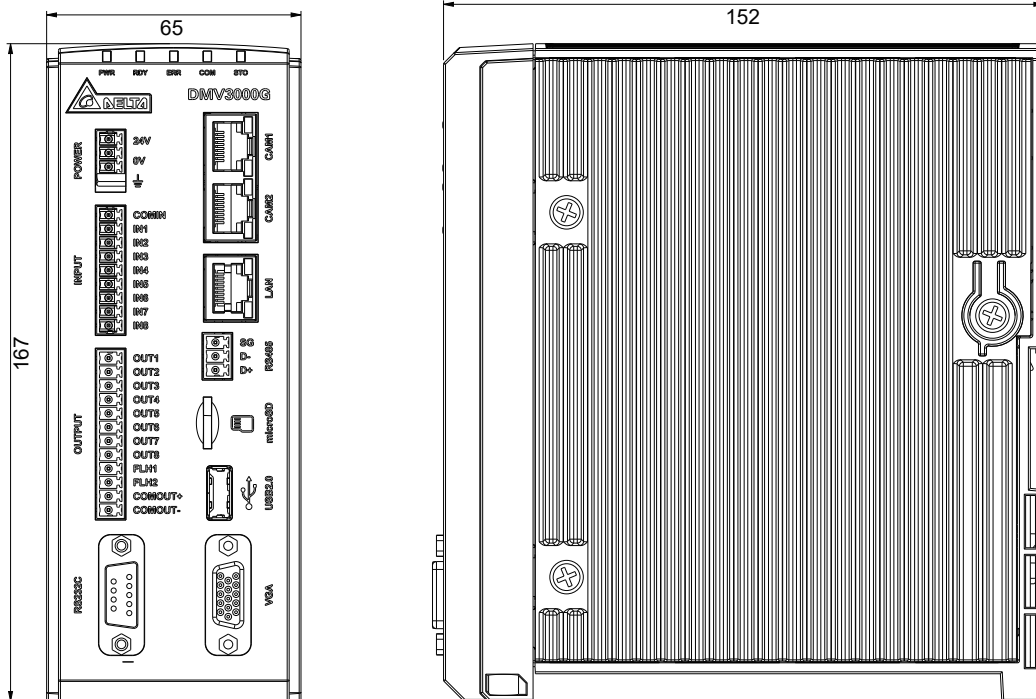

Cameras for DMV3000G

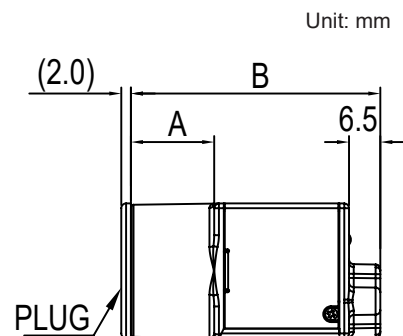
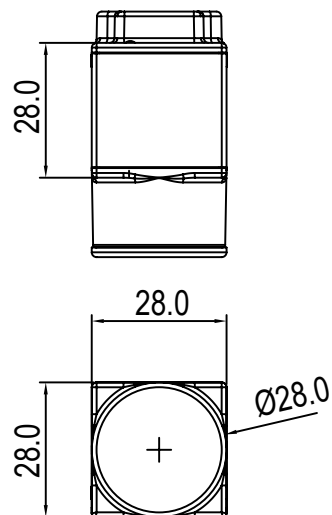

Dimensions	A	B
DMV-CM2MXXX-D	17.30 mm	51.80 mm
DMV-CM30XXX-D	16.18 mm	50.68 mm

DMV2000 Controller

Unit: mm

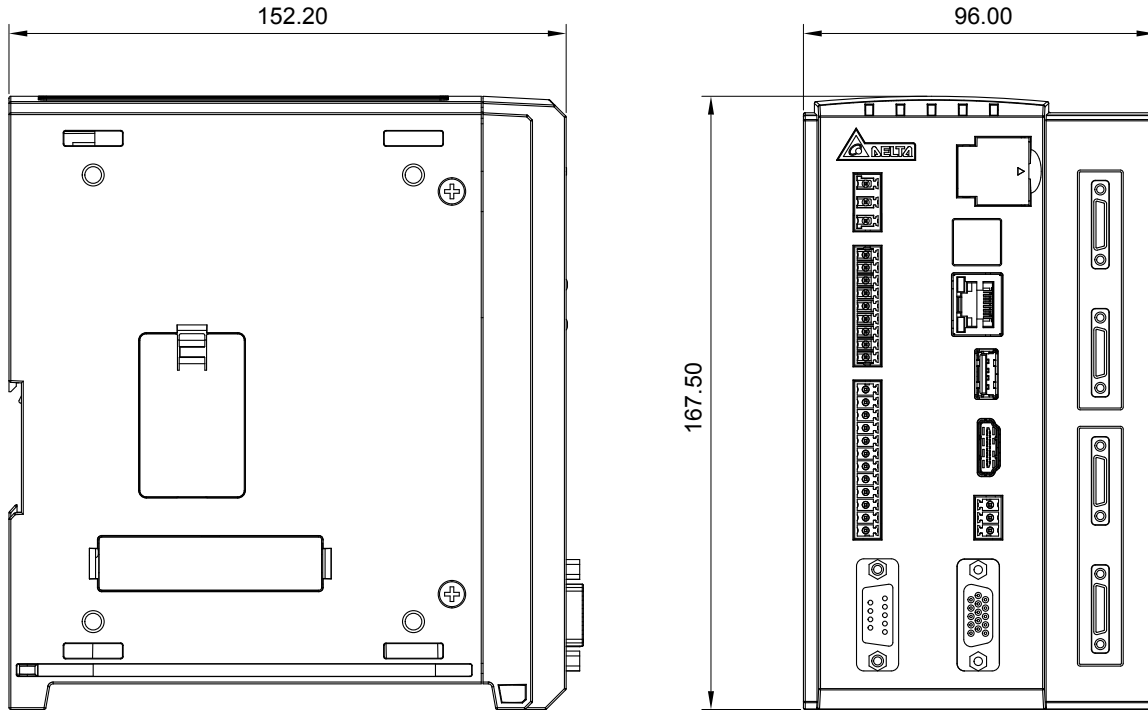

Cameras for DMV2000

CMOS 0.3M

Unit: mm

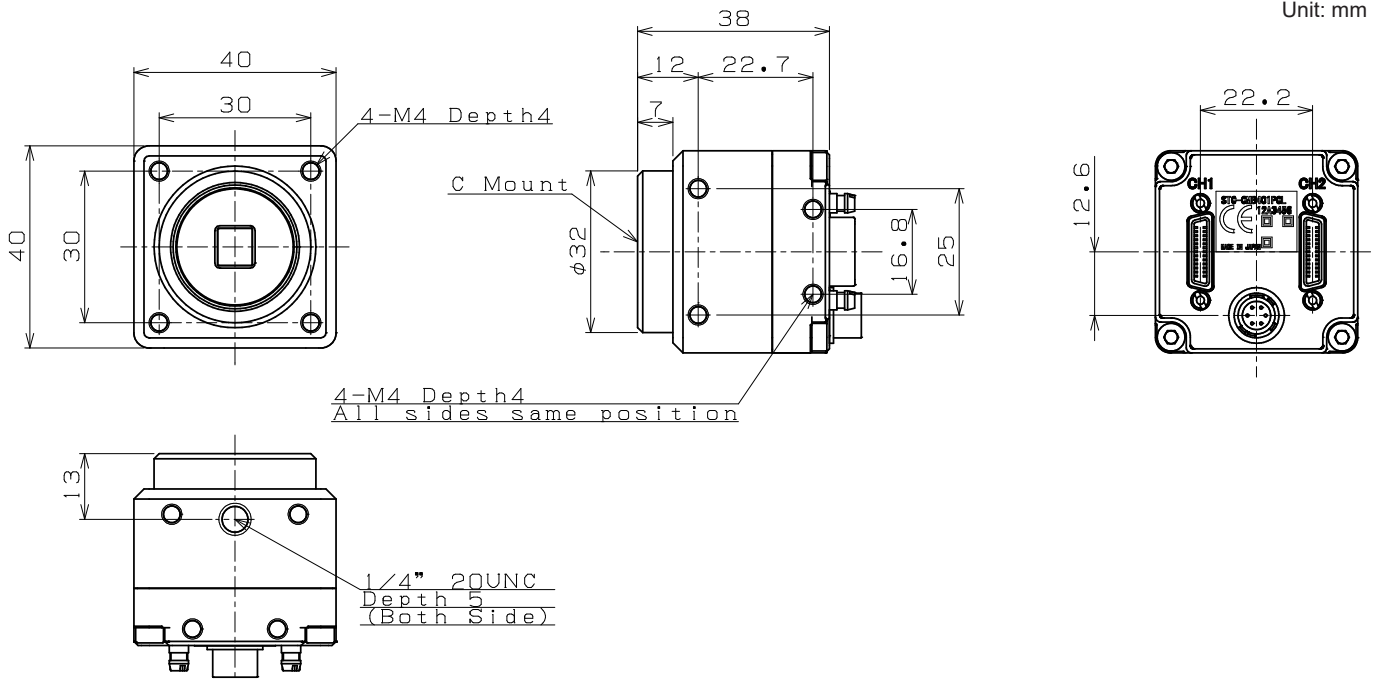

Dimensions

Cameras for DMV2000

CMOS 2M / 4M

Unit: mm

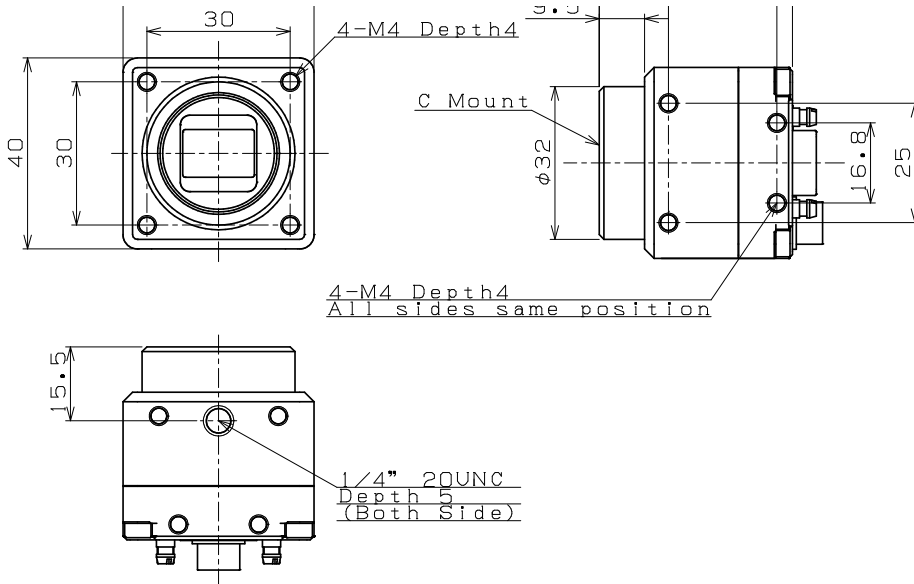

CMOS 5M

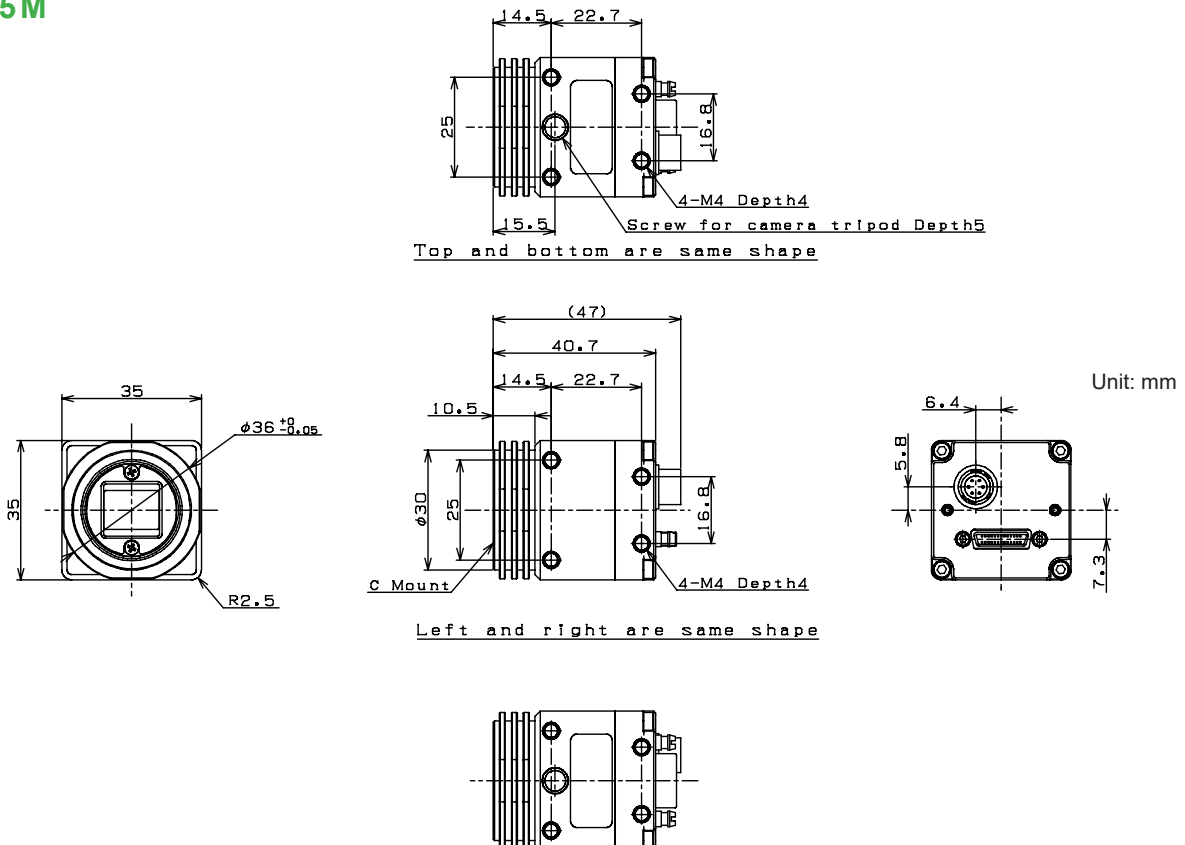

Dimensions

DMV1000G Controller

Unit: mm

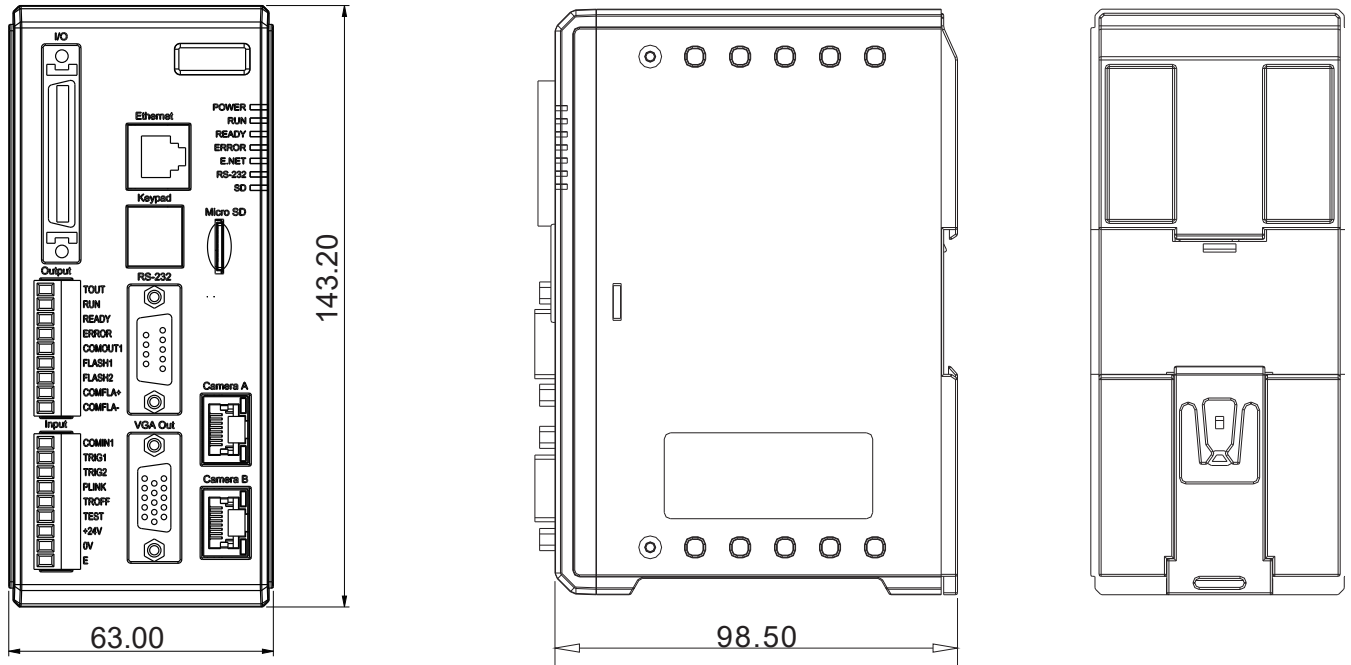

DMV1000G Joystick

Unit: mm

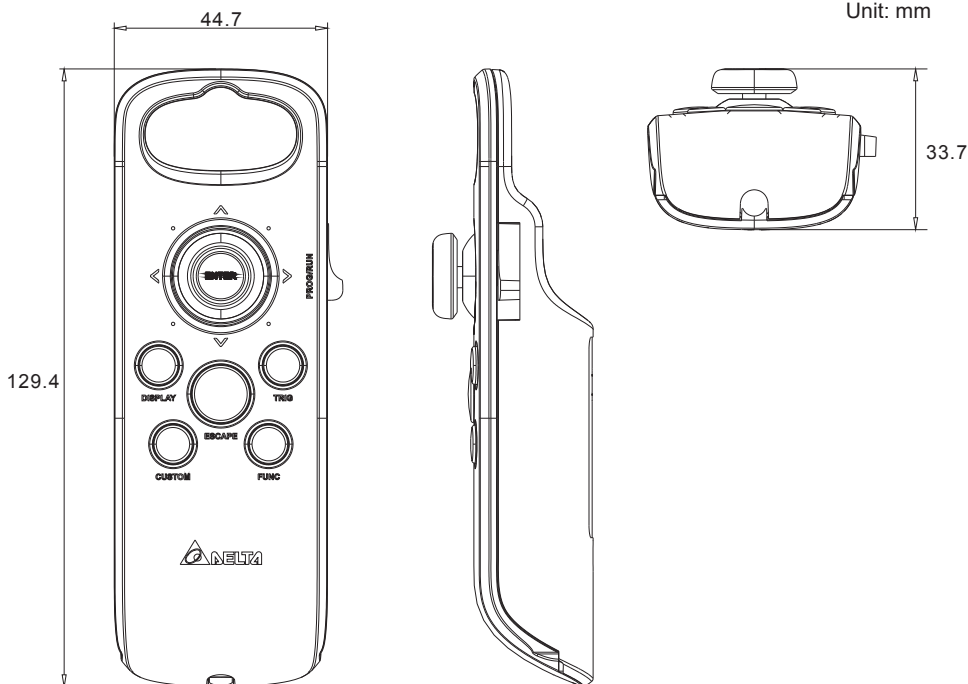

Camera for DMV1000G

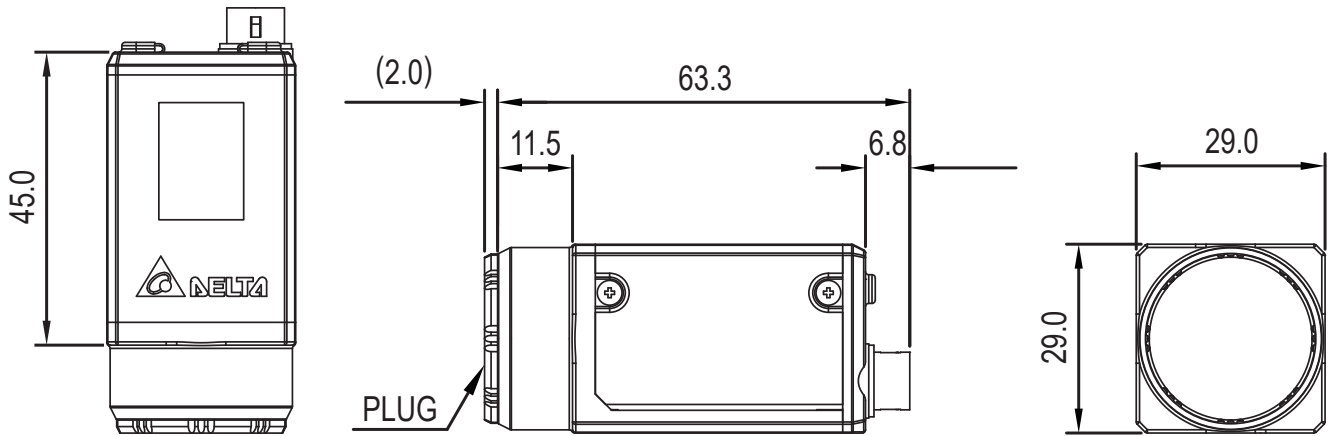

Unit: mm

Ordering Information

▪ Controllers

DMV3000G	DMV3000-GE2-VL	Standard controller for max. 2 cameras connectable
DMV2000	DMV2000-CL2-HS	Standard controller for max. 2 cameras connectable
	DMV2000-CL4-HS	Standard controller for max. 4 cameras connectable
DMV1000G	DMV1000-GE2-VL	Standard controller for max. 2 cameras connectable

▪ High-speed Camera Cables

DMV1000G DMV3000G	DMV-CAF5MGE	GigE FLEX cable (5M, flexible)
	DMV-CAF10MGE	GigE FLEX cable (10M, flexible)
DMV2000	DMV-CAF03CL	CameraLink FLEX cable (3M, flexible)
	DMV-CAF05CL	CameraLink FLEX cable (5M, flexible)

▪ Joystick

DMV1000G	DMV1000-KEY	Specifically for DMV1000G
-----------------	--------------------	---------------------------

▪ Illumination

DMV3000G DMV2000 DMV1000G	DMV-CX40W	Coaxial white light
	DMV-DR6736R	Direct ring (red)
	DMV-DR6736W	Direct ring (white)
	DMV-DR6736D	Diffusion board
	DMV-BL60R	Back light (red)

Ordering Information

▪ Cameras

DMV3000G	DMV-CM30CGE-D	CMOS CAMERA 0.3M COLOR GigE (640x480)
	DMV-CM30GGE-D	CMOS CAMERA 0.3M MONO GigE (640x480)
	DMV-CM2MCGE-D	CMOS CAMERA 2.0M COLOR GigE (1600x1200)
	DMV-CM2MGGE-D	CMOS CAMERA 2.0M MONO GigE (1600x1200)
DMV2000	DMV-CM30CCL	CMOS CAMERA 0.3M COLOR CameraLink (640x480)
	DMV-CM30GCL	CMOS CAMERA 0.3M MONO CameraLink (640x480)
	DMV-CM2MCCL	CMOS CAMERA 2.0M COLOR CameraLink (2048x1088)
	DMV-CM2MGCL	CMOS CAMERA 2.0M MONO CameraLink (2048x1088)
	DMV-CM4MCCL	CMOS CAMERA 4.0M COLOR CameraLink (2048x2048)
	DMV-CM4MGCL	CMOS CAMERA 4.0M MONO CameraLink (2048x2048)
	DMV-CM5MCCL	CMOS CAMERA 5.0M COLOR CameraLink (2448x2048)
DMV1000G	DMV-CV800GM060	CCD CAMERA 0.8M MONO IEEE1394 (1024x768)
	DMV-CV300GM120	CCD CAMERA 0.3M MONO IEEE1394 (640x480)

▪ Power Supply (for LED Illumination)

DMV3000G DMV2000 DMV1000G	DMV-PS12C1	Single-channel output
	DMV-PS12C2	Dual-channel output
	DMV-CA30P	Extension cable for illumination



Ordering Information

▪ Cameras

Controller		DMV1000G		
Camera				
Camera	Lens	DMV-CV300GM120	DMV-CV800GM060	DMV-CM30GCL DMV-CM30CCL
DMV-LN06W40	0.4 M 2/3" 6 mm	●		●
DMV-LN08W40	0.4 M 2/3" 8 mm	●		●
DMV-LN12W40	0.4 M 2/3" 12 mm	●		●
DMV-LN16W40	0.4 M 2/3" 16 mm	●		●
DMV-LN25W40	0.4 M 2/3" 25 mm	●		●
DMV-LN35W40	0.4 M 2/3" 35 mm	●		●
DMV-LN50W40	0.4 M 2/3" 50 mm	●		●
DMV-LN75W40	0.4 M 2/3" 75 mm	●		●
DMV-LN100W40	0.4 M 2/3" 100 mm	●		●
DMV-LN05M	2 M 2/3" 5 mm	○	●	○
DMV-LN06M	2 M 2/3" 6 mm	○	●	○
DMV-LN08M02	2 M 2/3" 8 mm	○	●	○
DMV-LN12M02	2 M 2/3" 12 mm	○	●	○
DMV-LN16M02	2 M 2/3" 16 mm	○	●	○
DMV-LN25M02	2 M 2/3" 25 mm	○	●	○
DMV-LN35M02	2 M 2/3" 35 mm	○	●	○
DMV-LN50M02	2 M 2/3" 50 mm	○	●	○
DMV-LN08M05-D	5 M 2/3" 8 mm	○	○	○
DMV-LN12M05-D	5 M 2/3" 12 mm	○	○	○
DMV-LN16M05-D	5 M 2/3" 16 mm	○	○	○
DMV-LN25M05-D	5 M 2/3" 25 mm	○	○	○
DMV-LN35M05-D	5 M 2/3" 35 mm	○	○	○
DMV-LN50M05-D	5 M 2/3" 50 mm	○	○	○
DMV-LN12M05	5 M 1" 12.5 mm	○	○	○
DMV-LN35M05	5 M 1" 35 mm	○	○	○
DMV-LN50M05	5 M 1" 50 mm	○	○	○
DMV-LN12M06	6 M 1" 12 mm	○	○	○
DMV-LN16M06	6 M 1" 16 mm	○	○	○
DMV-LN25M06	6 M 1" 25 mm	○	○	○
DMV-LN35M06	6 M 1" 35 mm	○	○	○
DMV-LN50M06	6 M 1" 50 mm	○	○	○

Description : ● = Standard ○ = Alternative

DMV2000			DMV3000G	
DMV-CM2MGCL DMV-CM2MCCL	DMV-CM4MGCL DMV-CM4MCCL	DMV-CM5MGCL DMV-CM5MCCL	DMV-CM30GGE-D DMV-CM30CGE-D	DMV-CM2MGGE-D DMV-CM2MCGE-D
			●	
			●	
			●	
			●	
			●	
			●	
			●	
			●	
●			○	●
●			○	●
●			○	●
●			○	●
●			○	●
●			○	●
●			○	●
●			○	●
○		●	○	○
○		●	○	○
○		●	○	○
○		●	○	○
○		●	○	○
○		●	○	○
○		●	○	○
○		●	○	○
○	●	●	○	○
○	●	●	○	○
○	●	●	○	○
○	●	●	○	○
○	●	●	○	○
○	●	●	○	○
○	●	●	○	○
○	●	●	○	○
○	●	●	○	○
○	●	●	○	○



Smarter. Greener. Together.

Industrial Automation Headquarters

Taiwan: Delta Electronics, Inc.

Taoyuan Technology Center
No.18, Xinglong Rd., Taoyuan District,
Taoyuan City 33068, Taiwan
TEL: +886-3-362-6301 / FAX: +886-3-371-6301

Asia

China: Delta Electronics (Shanghai) Co., Ltd.

No.182 Minyu Rd., Pudong Shanghai, P.R.C.
Post code : 201209
TEL: +86-21-6872-3988 / FAX: +86-21-6872-3996
Customer Service: 400-820-9595

Japan: Delta Electronics (Japan), Inc.

Industrial Automation Sales Department
2-1-14 Shibadaimon, Minato-ku
Tokyo, Japan 105-0012
TEL: +81-3-5733-1155 / FAX: +81-3-5733-1255

Korea: Delta Electronics (Korea), Inc.

1511, 219, Gasan Digital 1-Ro., Geumcheon-gu,
Seoul, 08501 South Korea
TEL: +82-2-515-5305 / FAX: +82-2-515-5302

Singapore: Delta Energy Systems (Singapore) Pte Ltd.

4 Kaki Bukit Avenue 1, #05-04, Singapore 417939
TEL: +65-6747-5155 / FAX: +65-6744-9228

India: Delta Electronics (India) Pvt. Ltd.

Plot No.43, Sector 35, HSIIDC Gurgaon,
PIN 122001, Haryana, India
TEL: +91-124-4874900 / FAX: +91-124-4874945

Thailand: Delta Electronics (Thailand) PCL.

909 Soi 9, Moo 4, Bangpoo Industrial Estate (E.P.Z),
Pattana 1 Rd., T.Phraksa, A.Muang,
Samutprakarn 10280, Thailand
TEL: +66-2709-2800 / FAX: +66-2709-2827

Australia: Delta Electronics (Australia) Pty Ltd.

Unit 20-21/45 Normanby Rd., Notting Hill Vic 3168, Australia
TEL: +61-3-9543-3720

Americas

USA: Delta Electronics (Americas) Ltd.

5101 Davis Drive, Research Triangle Park, NC 27709, U.S.A.
TEL: +1-919-767-3813 / FAX: +1-919-767-3969

Brazil: Delta Electronics Brazil

Rua Itapeva, 26 - 3º, andar Edifício Itapeva,
One - Bela Vista 01332-000 - São Paulo - SP - Brazil
TEL: +55-12-3932-2300 / FAX: +55-12-3932-237

Mexico: Delta Electronics International Mexico S.A. de C.V.

Gustavo Baz No. 309 Edificio E PB 103
Colonia La Loma, CP 54060
Tlalnepantla, Estado de México
TEL: +52-55-3603-9200

EMEA

EMEA Headquarters: Delta Electronics (Netherlands) B.V.

Sales: Sales.IA.EMEA@deltaww.com
Marketing: Marketing.IA.EMEA@deltaww.com
Technical Support: iatechnicalsupport@deltaww.com
Customer Support: Customer-Support@deltaww.com
Service: Service.IA.emea@deltaww.com
TEL: +31(0)40 800 3900

BENELUX: Delta Electronics (Netherlands) B.V.

Automotive Campus 260, 5708 JZ Helmond, The Netherlands
Mail: Sales.IA.Benelux@deltaww.com
TEL: +31(0)40 800 3900

DACH: Delta Electronics (Netherlands) B.V.

Coesterweg 45, D-59494 Soest, Germany
Mail: Sales.IA.DACH@deltaww.com
TEL: +49(0)2921 987 0

France: Delta Electronics (France) S.A.

ZI du bois Challand 2, 15 rue des Pyrénées,
Lisses, 91090 Evry Cedex, France
Mail: Sales.IA.FR@deltaww.com
TEL: +33(0)1 69 77 82 60

Iberia: Delta Electronics Solutions (Spain) S.L.U

Ctra. De Villaverde a Vallecas, 265 1º Dcha Ed.
Hormigueras – P.I. de Vallecas 28031 Madrid
TEL: +34(0)91 223 74 20

Carrer Llacuna 166, 08018 Barcelona, Spain

Mail: Sales.IA.Iberia@deltaww.com

Italy: Delta Electronics (Italy) S.r.l.

Via Meda 2-22060 Novedrate(CO)
Piazza Grazioli 18 00186 Roma Italy
Mail: Sales.IA.Italy@deltaww.com
TEL: +39 039 8900365

Russia: Delta Energy System LLC

Vereyskaya Plaza II, office 112 Vereyskaya str.
17 121357 Moscow Russia
Mail: Sales.IA.RU@deltaww.com
TEL: +7 495 644 3240

Turkey: Delta Greentech Elektronik San. Ltd. Sti. (Turkey)

Şerifali Mah. Hendem Cad. Kule Sok. No:16-A
34775 Ümraniye – İstanbul
Mail: Sales.IA.Turkey@deltaww.com
TEL: + 90 216 499 9910

MEA: Eltek Dubai (Eltek MEA DMCC)

OFFICE 2504, 25th Floor, Saba Tower 1,
Jumeirah Lakes Towers, Dubai, UAE
Mail: Sales.IA.MEA@deltaww.com
TEL: +971(0)4 2690148